

TOSHIBA

Portable Printer

Owner's Manual

B-FP2D-GH30-QM-S

B-FP2D-GH50-QM-S

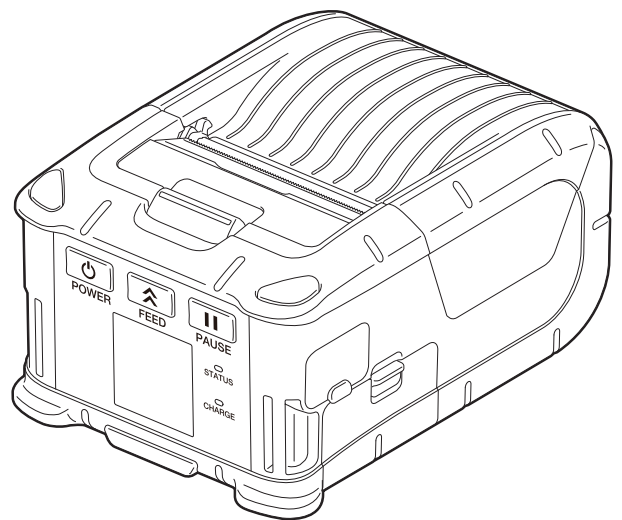

CONTENTS

| | |
|--|-----------|
| 1. Precautions | 3 |
| 2. Part Names | 10 |
| 3. Accessories | 11 |
| 4. Operation Panel Functions | 12 |
| 5. Loading the Battery Pack | 14 |
| 6. Removing the Battery Pack | 16 |
| 7. Charging the Battery Pack with an Optional Adapter | 17 |
| 8. Loading the Media Roll | 18 |
| 9. Before using the Peel-off Unit | 20 |
| How to put away the peel-off roller | 22 |
| 10. How to Attach the Accessories | 23 |
| Belt clip | 23 |
| Shoulder strap (Option) | 24 |
| 11. Data Transmission | 25 |
| USB | 25 |
| Wireless | 26 |
| 12. Daily Maintenance | 27 |
| Print head | 27 |
| Platen and the strip shaft | 27 |
| Media sensor window and the media path | 28 |
| Top cover and the operation panel | 28 |
| 13. Troubleshooting | 29 |
| 14. Printer Specification | 32 |
| 15. Media Specification | 33 |
| 16. Care/Handling of the Media Roll | 35 |

1. Precautions

CE compliance

This product is labelled with the CE mark in accordance with the provisions of the applicable European Directives for this product and the electric accessories.

CE marking is the responsibility of Toshiba Tec Germany Imaging Systems GmbH, Carl-Schurz-Str. 7, 41460 Neuss, Germany, phone +49-(0)-2131-1245-0.

For a copy of the related CE Declaration of Conformity, please contact your dealer, Toshiba Tec Germany Imaging Systems GmbH or Toshiba Tec Corporation.

UKCA compliance:

This product is labelled with the UKCA mark in accordance with the provisions of the applicable UK legislations for this product and the electric accessories.

UKCA marking is the responsibility of Toshiba Tec U.K. Imaging Systems Ltd, Abbey Cloisters, Abbey Green, Chertsey, Surrey, KT16 8RB, phone +44-(0)-843 2244944.

For a copy of the related UKCA Declaration of Conformity, please contact your dealer, Toshiba Tec U.K. Imaging Systems Ltd or Toshiba Tec Corporation.

FCC Notice

This equipment has been tested and found to comply with the limits for a Class A digital device, pursuant to part 15 of the FCC Rules. These limits are designed to provide reasonable protection against harmful interference when the equipment is operated in a commercial environment. This equipment generates, uses, and can radiate radio frequency energy and, if not installed and used in accordance with the instruction manual, may cause harmful interference to radio communications. Operation of this equipment in a residential area is likely to cause harmful interference in which case the user will be required to correct the interference at his own expense.

Some types of this product are equipped with a wireless communication device, such as, MBH7BTZ42 and RS9113DB. Please be sure to read the enclosed Precautions for Handling of Wireless Communication Devices before using this product.

Note:

When you purchase interface cables on the market, shielded cables must be chosen and used.

This product is designed for commercial usage and is not consumer product.

CALIFORNIA PROPOSITION 65 WARNING

WARNING:

This product can expose you to chemicals including DINP, which is/are known to the State of California to cause cancer, and chemicals including Phthalate[s], which is/are known to the State of California to cause birth defects or other reproductive harm.

For more information go to:
www.P65Warnings.ca.gov



Complies with
IMDA Standards
DA105848



CAUTION!

- Only use Toshiba Tec battery packs designed and manufactured for use with the specific printer model. The battery used in this device may present a risk of fire or chemical burn if mistreated. Do not disassemble, heat above +50degC, or incinerate. Replace battery with the B-FP2D series only. There is a risk of fire or explosion if the battery is replaced by an incorrect type.

B-FP2D-GH30-QM-S/B-FP2D-GH50-QM-S → B-FP803-BTH-QM-R

- Dispose of used battery promptly. Keep away from children. Do not disassemble and do not dispose of in fire.
- When an external power source such as an AC adapter is connected to the printer, DO NOT use any device other than an exclusive one.

AC adapter: B-FP800-AC-QM-S (Model: FSP065-RBBN3)



This product is marked according to the requirement on Waste electrical and electronic equipment - WEEE.

The use of the symbol indicates that product may not be disposed as unsorted municipal waste and has to be collected separately. By ensuring this product is disposed of correctly, you will help prevent potential negative consequences for the environment and human health, which could otherwise be caused by inappropriate waste handling of this product.

For more detailed information about the take-back and recycling of this product please contact your supplier where you purchased the product.



This symbol is applicable for EU member states only

Battery users must not dispose of batteries as unsorted general waste, but treat properly.

For Turkey

AEEE Yönetmeliğine Uygundur

Following information is only for India:

The use of the symbol indicates that this product may not be treated as household waste. By ensuring this product is disposed of correctly, you will help prevent potential negative consequences for the environment and human health, which could otherwise be caused by inappropriate waste handling of this product.

For more detailed information about the take-back and recycling of this product, please contact your supplier where you purchased the product. This product including components, consumables, parts and spares complies with the "India E-Waste Rules " and prohibits use of lead, mercury, hexavalent chromium, polybrominated biphenyls or polybrominated diphenyl ethers in concentrations exceeding 0.1% by weight and 0.01% by weight for cadmium, except for the exemption set in the Rule.



Precautions for Handling of Wireless Communication Devices

Bluetooth® Module: MBH7BTZ42

Wireless LAN Module: RS9113DB

Trademark

Bluetooth is a registered trademark owned by Bluetooth SIG, Inc. and used by Toshiba Tec Corporation under license.

Cautions

General

For all countries and areas

This product is a wireless communication device, and the use of this product is restricted to the following countries or areas. If the product is used in the countries or areas other than the following, you may be punished according to the laws of those countries or areas.

USA, Canada, Chile, Mexico, Austria, Belgium, Bulgaria, Croatia, Cyprus, Czech Republic, Denmark, Estonia, Finland, France, Germany, Greece, Hungary, Ireland, Italy, Latvia, Lithuania, Luxembourg, Netherlands, Poland, Portugal, Romania, Slovakia, Slovenia, Spain, Sweden, United Kingdom, Switzerland, Norway, Iceland, Liechtenstein, Australia, New Zealand, China, Korea, Taiwan, Hong Kong, Malaysia, Turkey, Singapore, Vietnam, India, South Africa, Russia

For USA

This device complies with Part 15 of the FCC Rules. Operation is subject to the following two conditions:

- (1) this device may not cause harmful interference, and
 - (2) this device must accept any interference received, including interference that may cause undesired operation.
- Changes or modification not expressly approved by manufacturer for compliance could void the user's authority to operate the equipment.

For Canada

This device contains licence-exempt transmitter(s) that comply with Innovation, Science and Economic Development Canada's licence-exempt RSS(s).

Operation is subject to the following two conditions:

- (1) this device may not cause interference,
- (2) this device must accept any interference, including interference that may cause undesired operation of the device.

L'émetteur exempt de licence contenu dans le présent appareil est conforme aux CNR d'Innovation, Sciences et Développement économique Canada applicables aux appareils radio exempts de licence.

L'exploitation est autorisée aux deux conditions suivantes:

- (1) L'appareil ne doit pas produire de brouillage;
- (2) L'appareil doit accepter tout brouillage radioélectrique subi, même si le brouillage est susceptible d'en compromettre le fonctionnement

To prevent radio interference to the licensed service, this device is intended to be operated indoors and away from windows to provide maximum shielding. Equipment that is installed outdoors is subject to licensing.

Without permission, any company, firm or user shall not alter the frequency, increase the power, or change the characteristics and functions of the original design of the certified lower power frequency electric machinery.

The application of low power frequency electric machineries shall not affect the navigation safety nor interfere a legal communication, if an interference is found, the service will be suspended until improvement is made and the interference no longer exists.

For safety

Do not use this product in locations where use may be forbidden, for example, in an aeroplane or a hospital. If you do not know the forbidden areas, please refer to and follow the airline company or medical institution guidelines. Flight instruments or medical equipment may be affected, causing a serious accident.

Since this product uses extremely low power compared with mobile phones, it cannot possibly interfere the pacemakers and defibrillators. However, if the use of this product should be likely to have affected the pacemaker or defibrillator, immediately stop using the product and contact your Toshiba Tec sales agent.

Do not disassemble, modify, or repair the product. Doing so may cause injury. Also, modification is against the Laws and Regulations for Radio Equipment. Please ask your Toshiba Tec sales agent for repair.

Precaution in use

This product communicates with other devices by radio. Depending on the installation location, orientation, environment, etc., its communication performance may deteriorate or devices installed near by may be affected.

Keep away from microwave devices.

Communication performance may deteriorate or a communication error may occur due to radio interference emitted from the microwave device.

Since the Bluetooth and wireless LAN use the same radio frequency band, each radio wave may interfere with each other when they are used at the same time, causing a deterioration of communication performance or a disconnection of network. If there is any problem with connection, please stop using either Bluetooth or wireless LAN.

Do not use the product on a metal table or near a metal object.

Communication performance may be deteriorated.

Module Name: MBH7BTZ42

Bluetooth version: V2.1 + EDR
Frequency: 2.4000 to 2.4835 GHz
Maximum Transmit: Class 2
Power: +4dBm (Except antenna gain)
Receive Sensitivity: -87 dBm
Data Rates: 1Mbps (Basic Rate)/2Mbps (EDR 2Mbps)/3Mbps (EDR 3Mbps)
Communication distance: 3m/360deg (For BA400 specification)
Certification (Module): TELEC/FCC/IC/EN
Antenna specification: Mono-pole antenna
Peak Gain: -3.6dBi (2.4GHz)

Module Name: RS9113DB

Standard: IEEE802.11 a / b / g / n
Frequency: 2412 MHz to 2484 MHz/4910 MHz to 5825 MHz
Spacing: 5 MHz (2.4GHz), 20 MHz (5GHz)
Channel: US: 1 to 11, 36 to 48, 52 to 64, 100 to 116, 120 to 128, 132 to 140, 149 to 165
Europe: 1 to 13, 36 to 48, 52 to 64, 100 to 140
Antenna: PCB Trace antenna (built-in module) @2.0dBi
Communication speed/Modulation: 802.11b: 1, 2, 5.5, 11 Mbps
802.11g: 6, 9, 12, 18, 24, 36, 48, 54 Mbps
802.11n: MCS0 to MCS7 with and without Short GI
OFDM with BPSK, QPSK, 16-QAM, and 64-QAM 802.11b with CCK and DSSS
Receive sensitivity: -97 dBm
Transmission output: 18 dBm

CAUTION!

- To avoid injury, be careful not to catch or jam your fingers while opening or closing the cover.
- Do not touch moving parts. To reduce the risk that fingers, jewelry, clothing, etc., be drawn into the moving parts, turn off the power switch to stop movement.

Safety Summary

Personal safety in handling or maintaining the equipment is extremely important. Warnings and Cautions necessary for safe handling are included in this manual. All warnings and cautions contained in this manual and written inside or outside of the printer should be read and understood before handling or maintaining the equipment.

Do not attempt to effect repairs to this equipment. If a fault occurs that cannot be rectified using the procedures described in this manual, turn off the power, then contact your authorised Toshiba Tec representative for assistance.

Safety Precautions

This Owner's Manual and the products (machines) which you have purchased contain indications which should be observed in order to use the machines safely and prevent harm to yourself and others and damage to property.

The meanings of these indications and symbols are given below.

Read these indications and become familiar with their contents before reading this Owner's Manual.

Precautions

The following precautions will help to ensure that this machine will continue to function correctly.

- Try to avoid locations that have the following adverse conditions:
 - Temperatures out of the specification
 - High Humidity
 - Direct sunlight
 - Excessive vibration
- The cover should be cleaned by wiping with a dry cloth or a cloth slightly dampened with a mild detergent solution. NEVER USE THINNER OR ANY OTHER VOLATILE SOLVENT on the plastic covers.
- USE ONLY Toshiba Tec SPECIFIED media.
- DO NOT STORE the media where it might be exposed to direct sunlight, high temperatures, high humidity, dust, or gas.
- Any data stored in the memory of the printer could be lost during a printer fault.
- DO NOT open the top cover and battery cover during operation. Doing so will stop printer operation.
- DO NOT scratch the surface of printed labels or receipt with a sharp object.
- Be sure to use a shielded interface cable.

CAUTION!

- This manual may not be copied in whole or in part without the prior written permission of Toshiba Tec.
- The contents of this manual may be changed without notification.
- Please refer to your local Authorised Service representative with regard to any queries you may have in this manual.

 WARNING!

Do not use the 5GHz band for communication outdoors. Using wireless devices outdoors on the 5GHz band is prohibited. To operate the wireless LAN of this product outdoors, only use the 2.4GHz band.

**WARNING**

This indicates that there is the risk of death or serious injury if the machines are handled improperly or contrary to this indication.

- If water or any other liquid enters the machine, turn off the power. Continuous use of the machine under such conditions may cause fire or electric shock.
- If the enclosure is damaged when dropped or subject to shock, turn off the power. Continuous use of the machine under such conditions may cause fire or electric shock.
- Avoid continuous exposure to direct sunlight or high temperature as this may cause fire.
- Do not remove covers or modify the machine by yourself. Doing so may cause fire or electric shock.
- Avoid water, operation with wet hands or cleaning with a moistened cloth. Failure to do this may cause fire or electric shock.
- Do not wipe the machine with a cloth moistened with thinner or other volatile solvent as this may cause fire or electric shock.
- DO NOT USE a spray cleaner containing flammable gas for cleaning this product, as this may cause a fire.
- Use the specified battery only. Failure to do this may cause fire or electric shock.
- Danger of explosion if the battery is incorrectly replaced. Replace the battery only with a Toshiba Tec Corporation, Battery Pack Model B-FP803-BTH-QM-R. Discard used batteries according to the manufacturer's instruction.
- Do not disassemble and modify the battery because it has a protection unit in it. Doing so may break the protection unit, causing the battery to heat up, burst or burn.
- If the battery gets wet, dry it completely. Using a wet battery may cause fire or electric shock.
- Be aware of the following precautions when using batteries. Otherwise they could heat up, burst or burn.
 - Do not throw the battery into fire or heat it with a microwave or oven, etc.
 - Do not load the battery with the electrodes reversed.
 - Do not connect the electrodes with metal objects like wire. Do not carry or store the battery along with metal objects such as necklaces, hairpins, etc.
 - Do not stick a needle into, hammer, step on, or drop the battery.
 - Do not solder the battery.
 - Do not leave the battery where the temperature is more than 50°centigrade, such as inside a car or in direct sunlight.

**CAUTION**

This indicates that there is the risk of personal injury or damage to objects if the machines are improperly handled contrary to this indication.

- Keep away from flame or other sources of heat. Failure to do this may cause fire or machine failure.
- Do not drop or shock the machine as this may cause machine failure. Doing so may cause machine failure.
- During lightning, turn off and keep away from the machine because of danger of electric shock and machine failure.
- Avoid locations subject to rapid change in temperature as this causes condensation, causing electric shock or machine failure.
- Do not damage the print head, platen or strip roller with a sharp object. Doing so may cause machine failure.
- Do not touch or contact the print head element with a hard object. Doing so may cause machine failure.
- Use the specified media only. Failure to do this may cause machine failure.
- Be sure to turn off the machine before replacing the battery, or machine failure may occur.
- Do not charge the battery near flame or under direct sunlight. High temperature may activate or damage the protection unit of the battery, disabling the electric charge or causing it to overheat, burst, or burn.
- Unload the battery when the machine will not be used for a longtime. Failure to do this may cause machine failure.
- Keep the battery away from flame, a heat source or other locations subject to high temperature. Failure to do this may cause it to over heat or burn.
- Do not force the battery into the machine or battery charger. Doing so may cause the battery to overheat, burst or burn. Check for the correct electrode.
- Do not connect the battery to a power outlet or a car cigarette lighter jack as this may cause the battery to overheat, burst or burn.
- Because the B-FP803-BTH-QM-R Series battery is exclusively for the B-FP2D-GH Series printer, respectively, do not use the battery in other machines. Doing so may damage the battery or affect the performance and life of the battery.

Importer (For EU, EFTA):

Toshiba Tec Germany Imaging Systems GmbH
Carl-Schurz-Str. 7, 41460 Neuss, Germany

Importer (For UK):

Toshiba Tec U.K. Imaging Systems Ltd
Abbey Cloisters, Abbey Green, Chertsey, Surrey, KT16 8RB, United Kingdom

Manufacturer:

Toshiba Tec Corporation
1-11-1, Osaki, Shinagawa-ku, Tokyo 141-8562, Japan

2. Part Names

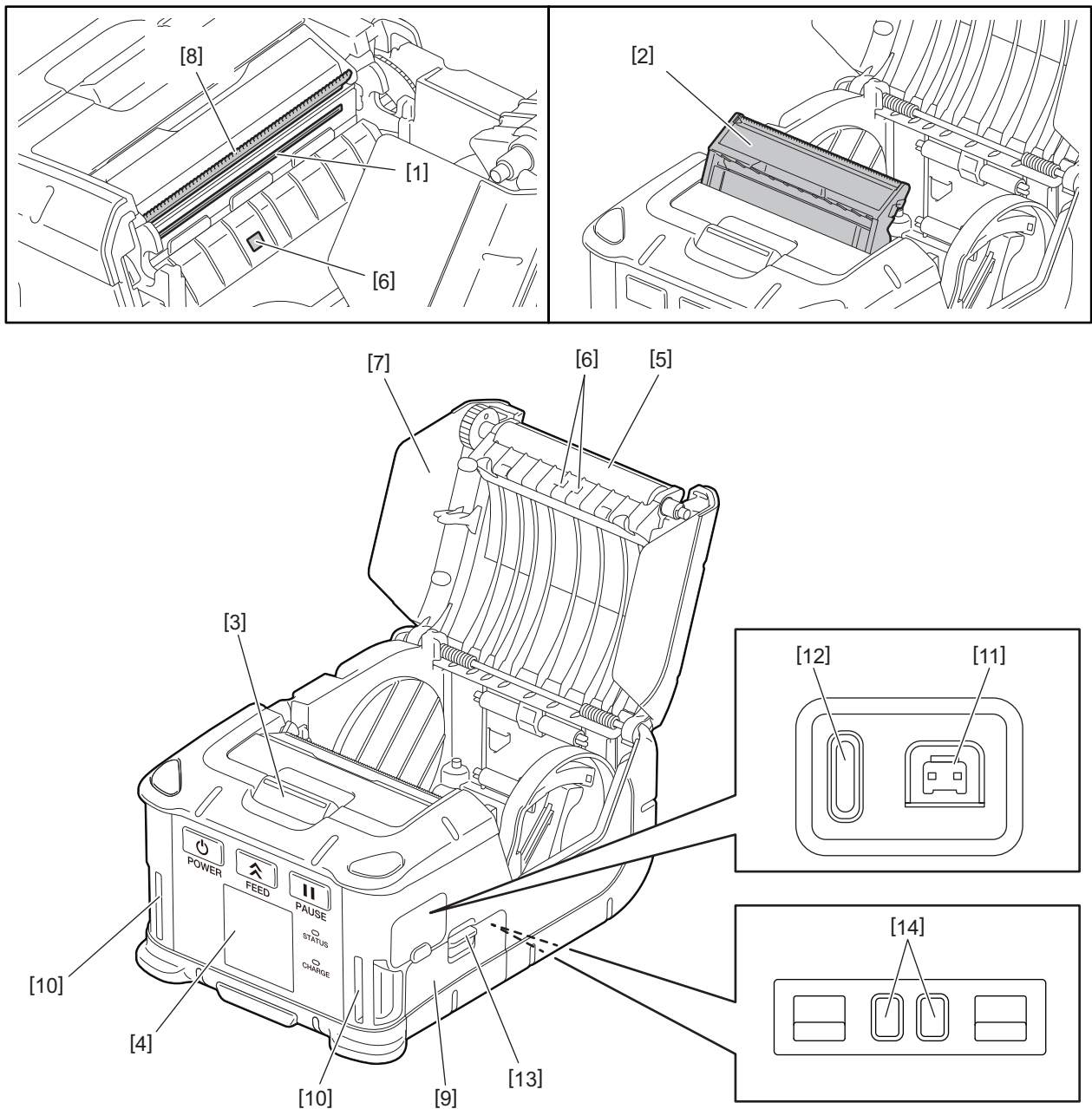

| No. | Part Name | No. | Part Name |
|-----|-----------------------|-----|-------------------|
| 1 | Print head | 11 | DCIN connector |
| 2 | Peel-off unit | 12 | USB port |
| 3 | Top cover open button | 13 | Battery lever |
| 4 | Operation panel | 14 | Charging terminal |
| 5 | Platen | | |
| 6 | Media sensor | | |
| 7 | Top cover | | |
| 8 | Tear bar | | |
| 9 | Battery cover | | |
| 10 | Strap slot | | |

3. Accessories

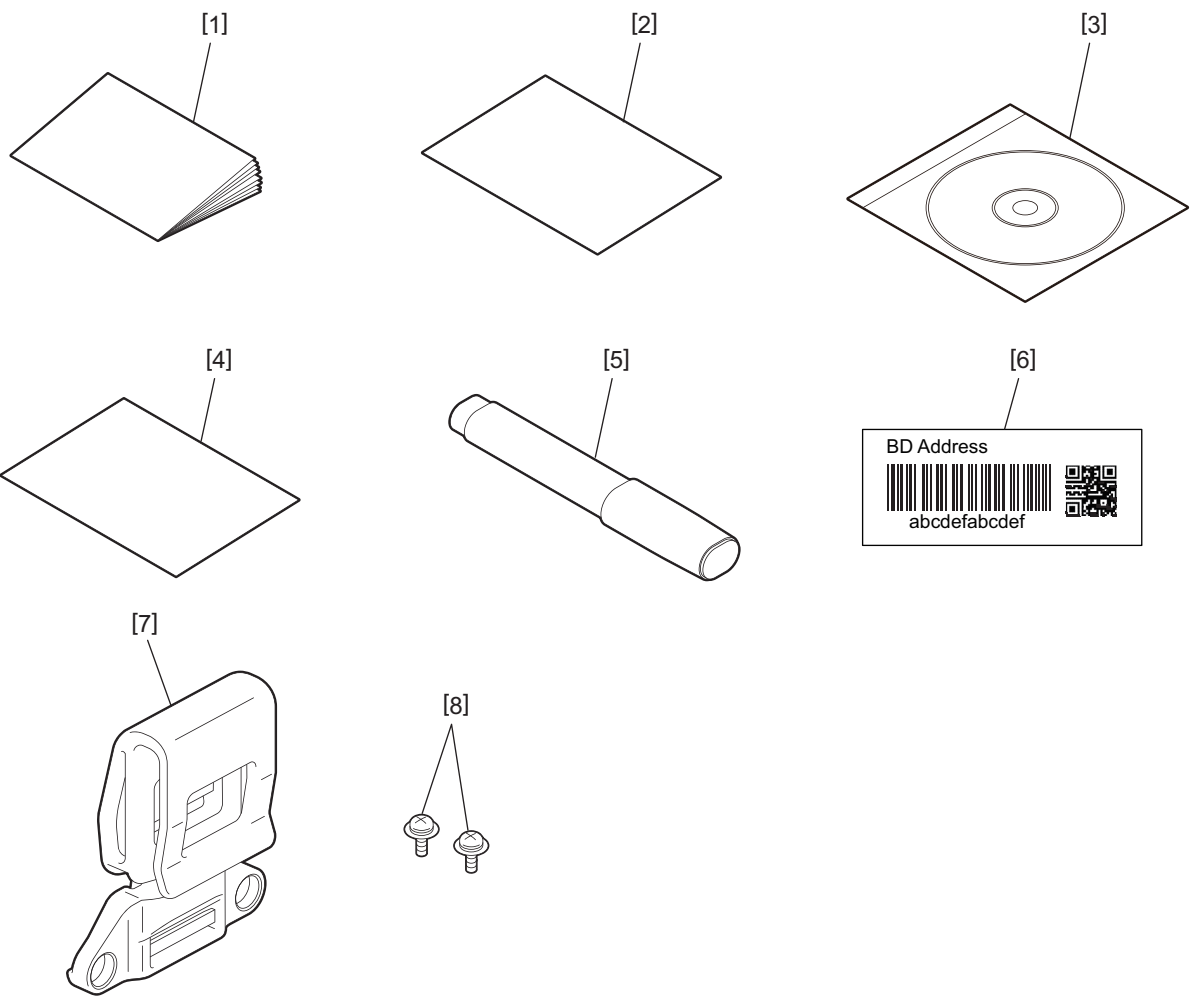

| No. | Part Name | No. | Part Name |
|-----|-------------------------|-----|--------------------|
| 1 | Owner's Manual | 5 | Print head cleaner |
| 2 | Safety Precaution Sheet | 6 | BD address label |
| 3 | CDROM | 7 | Belt clip |
| 4 | OTF License Guide | 8 | M-3x8 screw |



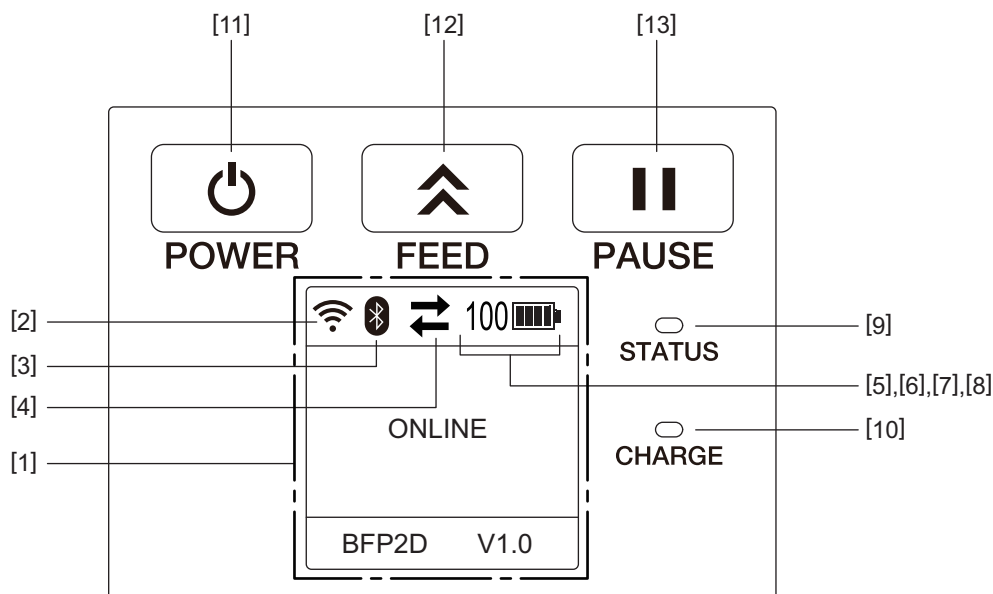



4. Operation Panel Functions



Note

Do not touch the operation panel with a sharp object, as its surface is easily damaged.

| No. | Name/Icon | Function/Usage | | |
|---------------|--|---|--|---|
| [1] | LCD (Liquid Crystal Display) | Displays the printer status icons, such as the radio intensity, battery level and etc. The printer status is indicated in alphanumeric characters or symbols. | | |
| | LCD Message | ONLINE | The printer is ready for an issue command from the host PC. | |
| | | PAUSE | The printer is in the pause state. When the printer is paused during printing, the number of unprinted labels is displayed. | |
| | | COVER OPEN | The top cover is open. | |
| | | LBL PRESENT **** | The printer is waiting for the printed label to be removed from the media outlet. "****" indicates the number of unprinted labels. | |
| WAITING(XXXX) | The printer is waiting for a recovery of the battery voltage or a temperature decrease in the print head or the motor. | | | |
| [2] | WLAN signal strength | | Indicates the WLAN intensity in 5 levels | |
| [3] | Bluetooth | | Bluetooth connected | Indicates the Bluetooth connection status |
| | | | Bluetooth not connected | |
| [4] | Transmission | | Data transmission/reception | Indicates the data transmission status |
| | | | Data receive by the printer | |
| | | | Data send to the host PC | |

| No. | Name/Icon | Function/Usage | | |
|------|----------------|---|--|--|
| [5] | Sleep |  | This is displayed while the printer is in the power save mode. | |
| [6] | Error |  | This is displayed when an error occurs in the printer. | |
| [7] | Battery level |  | Indicate the battery level in 10 levels and percentage level | |
| [8] | Parts Alert |  | Platen Roller Near Alert | Indicates the time to change the platen roller soon. |
| | |  | Platen Roller Alert | Indicates the time to change the platen roller. |
| | |  | Thermal Head Near Alert | Indicates the time to change the thermal head soon. |
| | |  | Thermal Head Alert | Indicates the time to change the thermal head. |
| [9] | STATUS lamp | <p>Lights or blinks in blue, red, purple or orange to indicate the printer status</p> <ul style="list-style-type: none"> • Lights up in blue: Normal state • Lights up in purple: Low-battery warning state (Operable) • Lights up in red: Low-battery state • Blinks in blue: Communicating or internal processing is in progress or a printed label is waiting to be removed. • Blinks in red: Error state | | |
| [10] | CHARGE lamp | Lights up in orange while the battery pack is charging and goes out when the battery charge is completed | | |
| [11] | [POWER] button | <p>Turns on or off the printer</p> <p>How to turn on the printer While the printer is off, hold down the [POWER] button for a few seconds. When “ONLINE” is displayed on the LCD, the printer is ready.</p> <p>How to turn off the printer Hold down the [POWER] button until the LCD goes off.</p> | | |
| [12] | [FEED] button | Feeds media or reprints previously printed data Function of the [FEED] button differs depending on the issue mode. | | |
| [13] | [PAUSE] button | Temporarily stops media issue or restarts printing This is used to recover the printer after clearing an error. | | |

5. Loading the Battery Pack

WARNING!

- If the battery pack leaks liquid or gives out smoke or a bad smell, immediately stop using it and keep it away from fire. Failure to do this may cause an explosion or a fire.
- In the United States, used lithium ion batteries should be returned to the store where you bought the machine. (USA only)
- LITHIUM ION BATTERY DISPOSE OF PROPERLY
- Do not handle a damaged or leaking lithium ion battery.
- To avoid injury, be careful not to drop the battery pack on your foot.

1 Press the battery lever [1] to open the battery cover [2].

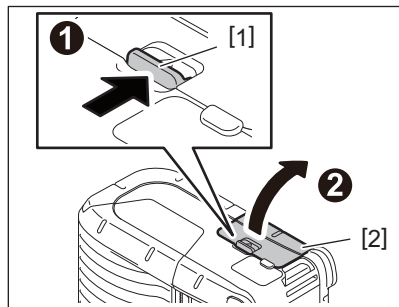

2 Insert the battery pack [3] fully into the printer.

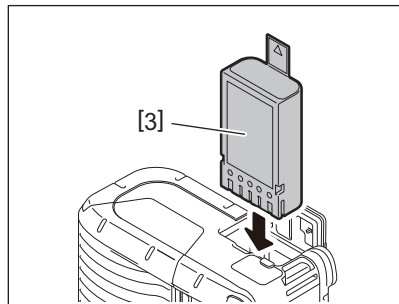

3 The battery pack [3] is locked in by the battery cover [2].

Note

Pay attention to the orientation of the battery pack [3].

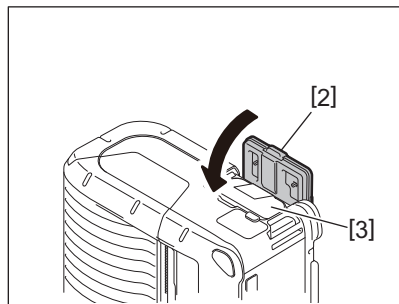

Note

- Be sure to use only the battery pack designed and manufactured for use with the printer B-FP2D series Battery Pack:
B-FP803-BTH-QM-R
- When unpacked, the battery level of the supplied battery pack is not full. Charge the battery pack with an optional battery charger or load the battery pack in the printer and connect an optional adapter before using it.
 - 1 slot battery charger (B-EP800-CHG-QM-R)
 - 6 slot battery charger (B-EP800-CHG6-QM-R)
 - AC adapter (B-FP800-AC-QM-S)
 - 1 slot cradle charger (B-FP802-CR-QM-S)
 - 4 slot cradle charger (B-FP802-CR4-QM-S)
 - DC jack plug adapter (B-FP800-DCJA-QM-R)
- When using 1 slot cradle charger, it is possible to print while charging.
- When using 4 slot cradle charger, it is not possible to print while charging.

CAUTION!

Do not connect any device other than the above to the printer.

6. Removing the Battery Pack

- 1** Press the battery lever [1] to open the battery cover [2].

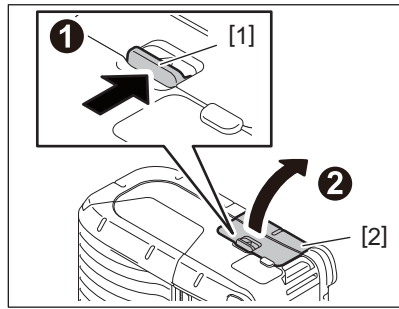

- 2** Pull the tab [4] to remove the battery pack [3] from the printer.

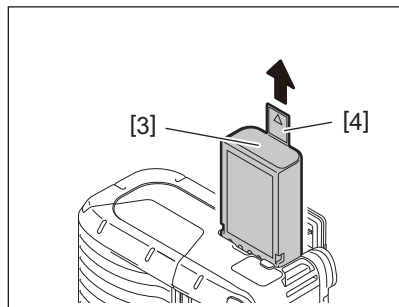

7. Charging the Battery Pack with an Optional Adapter

Charge the battery pack in the printer using an optional AC adapter, cigarette lighter adapter, or DC adapter.

1 Open the cover [1].

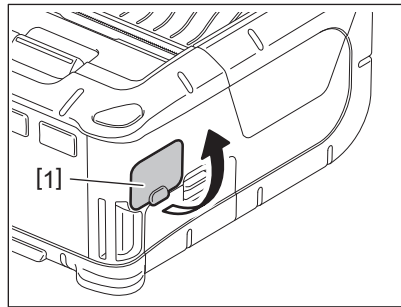

2 Connect the power adapter cable [2] into the DCIN connector [3].

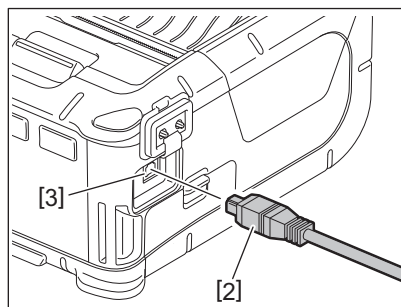

Note

- For details, refer to the Owner's Manual for the respective optional adapters.
- When using an optional battery charger to charge the battery packs, refer to the Owner's Manual for the respective models of battery chargers.

8. Loading the Media Roll

- 1 Push the top cover open button [1] to open the top cover [2].

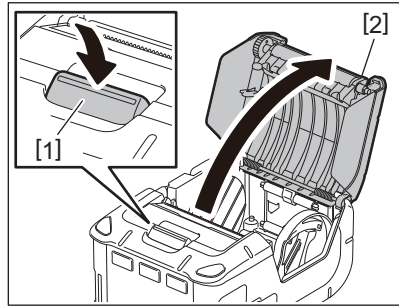

CAUTION!

The print head becomes hot immediately after printing. Let the print head cool down before loading the media roll.

- 2 Move the paper guide lever [3] toward the operation panel side and the paper guides [4] outward.

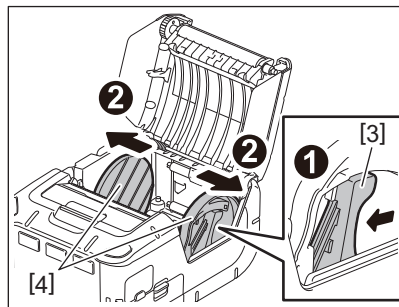

Note

Do not move the paper guides without unlocking the paper guide lever. This may cause a breakage of the paper guides.

- 3 Place the media roll [5] in the printer.

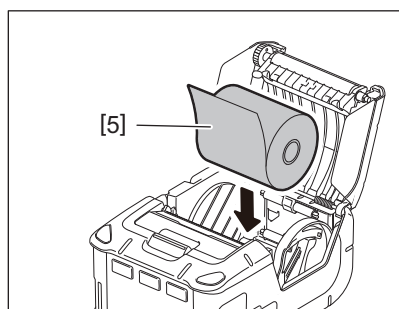

Note

- Use caution when working with the tear bar. The edge is sharp.
- Only outside wound media roll can be used in this printer.

-
- 4** Move the paper guide lever [3] toward the operation panel side. Adjust the paper guides [4] to the media roll width.

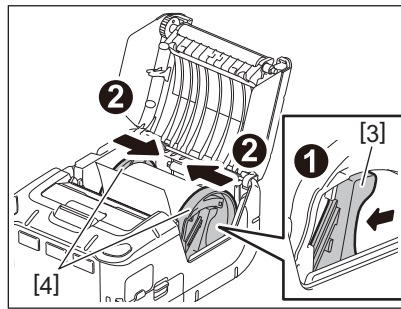

- 5** Pull the top edge of the media roll [5] toward the operation panel side. Remove the slack of the media roll and close the top cover [2].

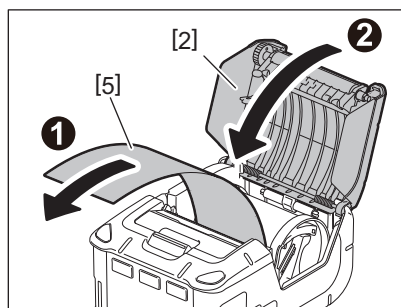

Note

- Use the Toshiba Tec approved media only. Toshiba Tec is not responsible for any print result caused by use of other media.
- When you order media, contact the nearest Toshiba Tec representative.

9. Before using the Peel-off Unit

When issuing labels in the peel-off mode, pull out the peel-off roller before loading a media roll.

- 1 Push the top cover open button [1] to open the top cover [2].**

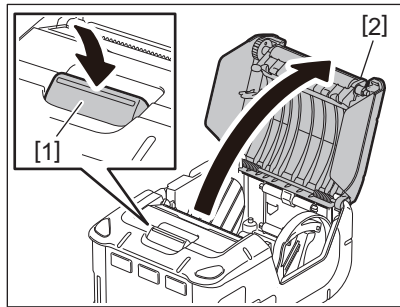

- 2 Push the lock lever [3] in the direction of the arrow. The peel-off unit [4] comes out.**

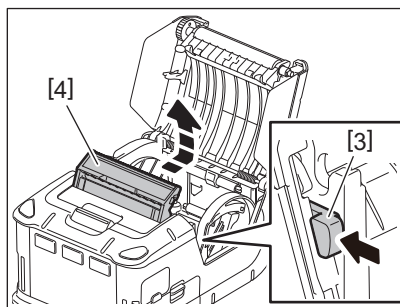

- 3 Refer to “Loading the Media Roll” on the previous page and set the media roll [5].**
Peel off one sheet of the label and dispose of it.

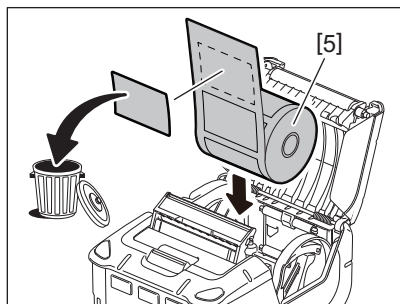

- 4 Move the paper guide lever [6] toward the operation panel side. Adjust the paper guides [7] to the media roll width.**

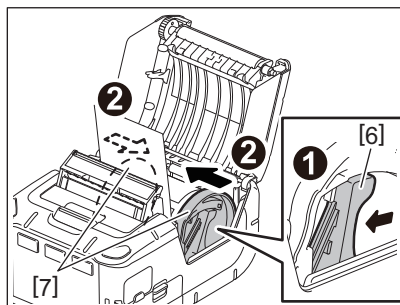

-
- 5** Pull the top edge of the media roll [5] toward the operation panel side. Remove the slack of the media roll and close the top cover [2].

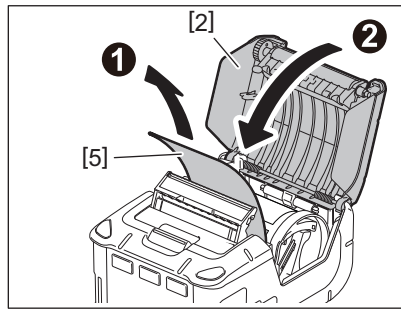

- 6** Close the peel-off unit [4].

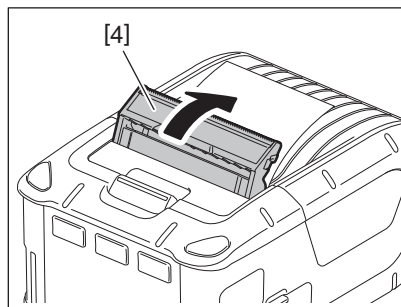

Note

- Do not pull the center of the peel-off roller hard. This may cause a breakage of the peel-off roller.
- Do not forcibly pull out the peel-off roller or push it into the printer. This may cause a breakage of the peel-off roller.
- Use caution when working with the tear bar. The edge is sharp.

■ How to put away the peel-off roller

- 1 Push the top cover open button [1] to open the top cover [2].

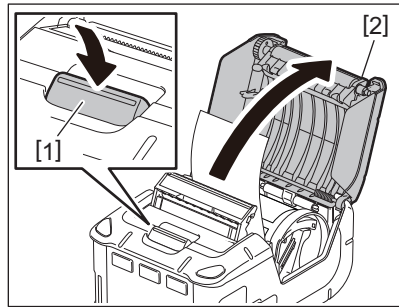

- 2 Gently press the peel-off roller [3] down and push it into the printer in the direction indicated by the arrow until it clicks.

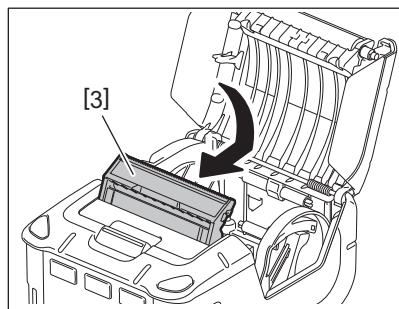

Note

- Do not pull the center of the peel-off roller hard. This may cause a breakage of the peel-off roller.
- Do not forcibly pull out the peel-off roller or push it into the printer. This may cause a breakage of the peel-off roller.
- Use caution when working with the tear bar. The edge is sharp.

10. How to Attach the Accessories

CAUTION!

- Care should be taken not to drop the printer when securing it to your waist or slinging it over your shoulder.
- For fixing the printer to your belt, its width should be 40 mm or less. Use of the other belts may cause the printer to fall off.

■ **Belt clip**

When you want to use the printer on belt, first secure the supplied belt clip to the rear of the printer.

1 Secure the belt clip [1] to the printer back with two screws (M-3x8) [2].

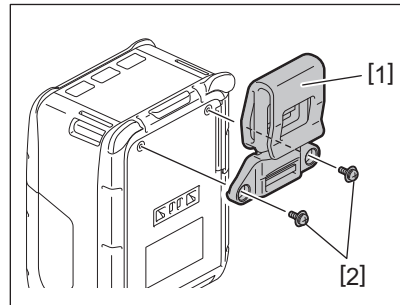

Note

Only use the supplied screws to secure the belt clip. Use of other screws may damage the inside of the printer.

2 Fasten the belt clip [1] to your belt [3].

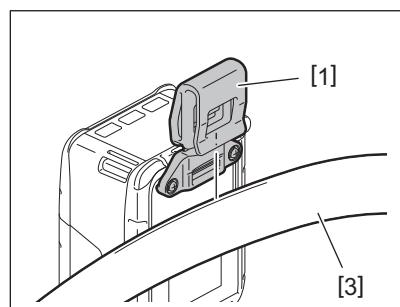

■ Shoulder strap (Option)

Follow the procedure below to fasten an optional shoulder strap (B-EP900-SS-QM-R) to the printer.

- 1** Pass either end of the shoulder strap [1] through the strap slot [2] on the front of the printer.
- 2** Pass the end of the shoulder strap [1] through the buckle [3]. Slide the buckle [3] to adjust the length of the shoulder strap [1].
- 3** Repeat for the other end of the shoulder strap [1].

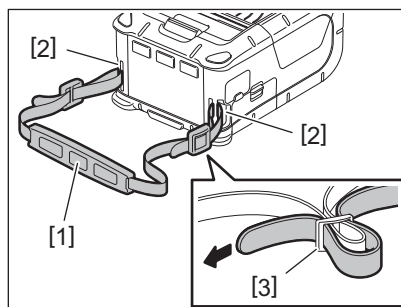

11. Data Transmission

■ USB

- 1 Turn on the host PC and start the system.
- 2 Turn on the printer and open the cover [1].

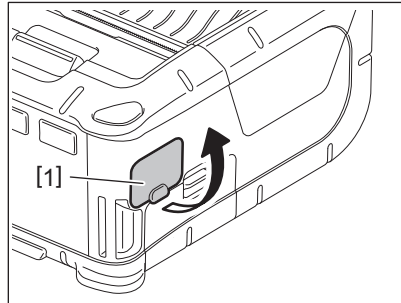

- 3 Connect the USB cable [2] to the USB port [3].

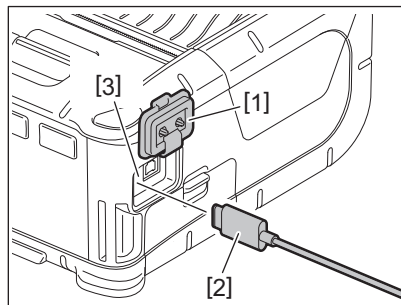

- 4 Connect the USB cable to the host PC.
- 5 Send data from the host PC to the printer.

Note

- For details of the USB cable, consult the nearest Toshiba Tec representative.
- When disconnecting the USB cable, follow the instructions of the system of the host PC.

■ Wireless

1 When using Bluetooth, make sure that the printer is placed within 3 m of the host PC. In the case of the wireless LAN, place the printer within a wireless coverage area.

2 Turn on the printer and the host PC. Then send data from the host PC to the printer.

1. Host PC
(Via Bluetooth)
2. Handy terminal
(Via Bluetooth)

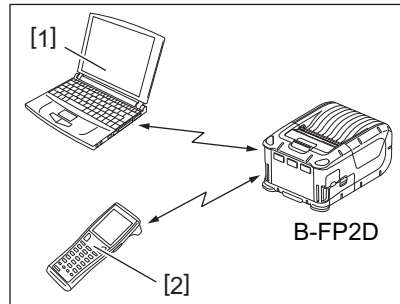

Note

- Be sure to read “Precautions for Handling of Wireless Communication Devices” before operating the printer.
- Confirm that there are no obstacles between the printer and the host PC. Obstacles may cause a communication failure.

The radio connectivity is affected by the operating environment. Especially, metal obstacles, metal powder or locations enclosed by metal walls may prevent proper communication. For the installation location of access points, consult the nearest Toshiba Tec representative.

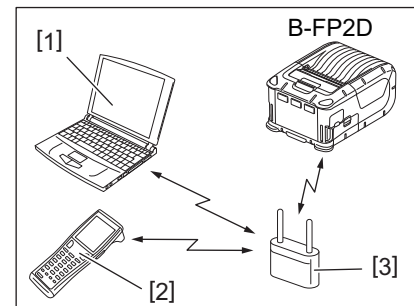

1. Host PC
2. Handy terminal
3. Access point

12. Daily Maintenance

To help retain the high performance quality of your printer, clean it regularly.

CAUTION!

- Do not use a sharp object to clean the print head or various rollers. This may cause a print failure or a breakdown of the printer.
- Never use any volatile solvent including thinner and benzene. This may cause a print failure or a breakdown of the printer.
- Do not touch the print head element with your bare hands. Otherwise, static discharge may damage the print head.
- The print head becomes hot immediately after printing. Allow it to cool before performing any maintenance.

■ Print head

Wipe the print head element [1] with a print head cleaner pen [2].

After one or two linerless label media rolls are used, wipe off any residual glue dirt from the print head.

Note

Use caution when working with the tear bar. The edge is sharp.

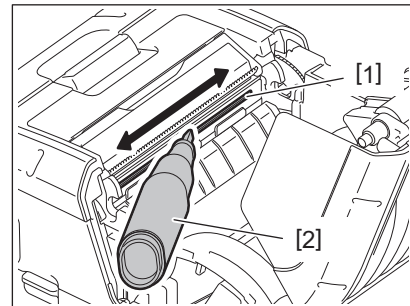

■ Platen and the strip shaft

While rotating the platen [1], wipe it with a soft cloth slightly moistened with absolute ethyl alcohol.

Wipe the strip shaft [2] with a soft cloth slightly moistened with absolute ethyl alcohol.

Clean the platen of the linerless label kit (B-FP902-LL-QM-S) in the same way. Cleaning should be performed after one or two linerless label media rolls are used.

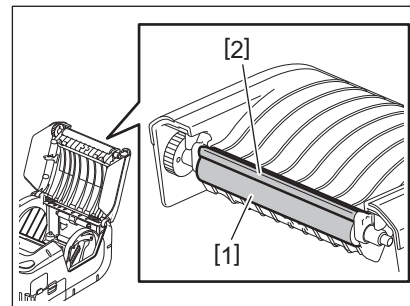

■ Media sensor window and the media path

Remove dust or dirt from the media sensor window [1] with a commercially available soft, dry brush.

Wipe the media path [2] with a soft, dry cloth.

After one or two linerless label media rolls are used, wipe off any residual glue dirt from the media guides.

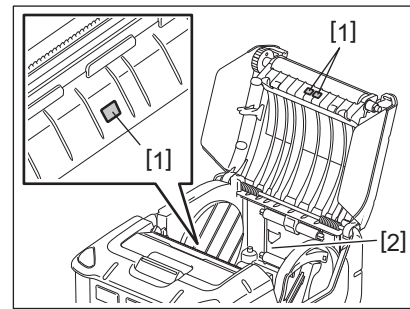

■ Top cover and the operation panel

Wipe the cover and operation panel window [2] with a soft cloth slightly moistened with absolute ethyl alcohol.

Remove any residual glue dirt from the media outlet [3] with a cotton swab slightly moistened with absolute ethyl alcohol.

After one or two linerless label media rolls are used, wipe off any residual glue dirt from the top cover [1] or the media outlet [3].

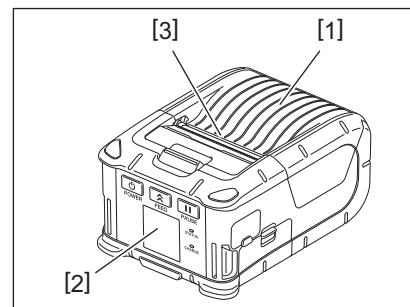

13. Troubleshooting

When a problem occurs during the operation, check the following troubleshooting guide and take the corrective action suggested.

When the problem still persists even if the following solutions have been performed, do not attempt to repair it by yourself. Turn off the printer and remove the battery pack. Then contact a Toshiba Tec service representative for assistance.

If an error message is displayed

When an error message is displayed, follow the respective instructions and press the [PAUSE] button. The error will be cleared.

| Error Message | Cause | Solution |
|-------------------|--|--|
| COMMS ERROR | A parity error or framing error has occurred during communication. | Turn the power off and then back on. Send data from the host PC to the printer again. If the problem recurs, turn off the power and contact a Toshiba Tec service representative. |
| PAPER JAM | The media roll is not loaded correctly. | Load the media roll correctly. |
| | The media has jammed in the printer. | Remove the jammed media and load the media roll correctly. Press the [PAUSE] button. |
| | The media roll has not been fed correctly. | Load the media roll correctly and press the [PAUSE] button. |
| | The reflective sensor does not detect black marks. | Load the correct media roll with black marks and press the [PAUSE] button. |
| | The transmissive sensor does not detect gaps between labels. | Load the correct media roll. If the problem recurs, set a threshold. |
| NO PAPER | The printer ran out of media roll. | Load a new media roll and press the [PAUSE] button. |
| COVER OPEN | The top cover is open. | Close the top cover. |
| HEAD ERROR | A part of the print head element is broken. | Turn off the printer and contact a Toshiba Tec service representative for replacement of the print head. |
| FLASH WRITE ERROR | A flash memory write error occurred. | Turn the power off and then back on. Send data from the host PC to the printer again. If the problem recurs, turn off the power and contact a Toshiba Tec service representative. |
| FORMAT ERROR | A flash memory format error occurred. | Turn the power off and then back on. Send data from the host PC to the printer again. If the problem recurs, turn off the power and contact a Toshiba Tec service representative. |
| FLASH MEMORY FULL | The flash memory has insufficient area for storing data. | Turn the power off and then back on. Re-format the memory to free up space then send data from the host PC to the printer again. If the problem recurs, turn off the power and contact a Toshiba Tec service representative. |
| LOW BATTERY | The remaining battery capacity is low. | Turn the power off and replace the battery pack with a fully charged one. |

| Error Message | Cause | Solution |
|---|--|--|
| EXCESS HEAD TEMPERATURE | The print head temperature reached the upper limit of the operating temperature. | Stop printing and wait until the printer is automatically restored. If the problem recurs, turn off the power and contact a Toshiba Tec service representative. |
| AMBIENT TEMP ERROR | The ambient temperature reached the upper limit of the operating temperature. | Stop printing until the ambient temperature falls within the printer's operating temperature range. |
| BATTERY TEMP ERROR | The battery is extremely hot. | Turn off the printer. Disconnect the power adapter if connected. Wait until the battery temperature falls within the printer's operating temperature range. |
| HIGH VOLT.ERROR | The battery voltage is abnormal. | Turn off the printer. Remove the battery pack, reload it, and turn on the printer again. If the problem recurs, turn off the power and contact a Toshiba Tec service representative. |
| CHARGE ERROR | An error was detected while charging the battery pack. | It could be the end of the battery life. Replace the battery pack with a new one. |
| Command error example PC001;0A00,0300, | When a command error occurs, up to 16 alphanumeric digits or symbols are displayed on the upper line of the LCD. | Turn the power off and then back on. Send data from the host PC to the printer again. If the problem recurs, turn off the power and contact a Toshiba Tec service representative. |
| Other error messages | A hardware or software failure occurs. | Turn the power off and then back on. If the problem recurs, turn off the power and contact a Toshiba Tec service representative. |

* The number of unprinted labels 1 to 9999 (in units of label)

When the printer does not operate properly

In the case of the following symptoms, check the respective points and take corrective action.

| Symptom | Point to check (Cause) | Solution |
|--|---|---|
| The printer is not turned on by pressing the [POWER] button. | The battery pack is not loaded correctly. | Load a fully charged battery pack. |
| A fully charged battery pack is loaded but the operating time is short. | The battery life is expired. | Load a fully charged new battery pack |
| The printer cannot communicate via the USB. | The printer is not turned on. | Turn on the printer. |
| | The printer is communicating via wireless communication. | Terminate the wireless communication. |
| | The issue mode is incorrect. | Select a correct issue mode. |
| The printer cannot communicate via Bluetooth. | The printer is not turned on. | Turn on the printer. |
| | The distance to the host PC is too far. | Bring the printer to within 3m of the host PC. |
| | The printer is used in a location where it is subjected to noise or interference. | Avoid such a location. |
| | The printer address is not correctly set on the host PC. | Set the correct printer address on the host PC. |
| | The issue mode is incorrect. | Select a correct issue mode. |
| The printer cannot communicate via wireless LAN. | The printer is not turned on. | Turn on the printer. |
| | The distance to the host PC is too far. | Bring the printer within a wireless coverage area. |
| | Obstacles block the radio wave. | Use the printer in a location with no obstacles. |
| | The printer is used in a location where it is subjected to noise or interference. | Avoid such a location. |
| | The printer address is not correctly set on the host PC. | Set the correct printer address on the host PC. |
| | The channel setting for the access point or host PC is incorrect. | Avoid using a channel which interferes with adjacent access points. |
| | The issue mode is incorrect. | Select a correct issue mode. |
| Printouts are too light. The printer received print data but does not print. | The print head is dirty. | Clean the print head. |
| | The media roll is not loaded properly. | Load the media roll properly. |
| | The media roll used has deteriorated past its use date. | Load a new media roll. |
| | The media is not a Toshiba Tec approved one | Use Toshiba Tec approved media. |
| The printer received print data but does not print. | The STATUS lamp is lit or blinking. | Clear the error. |
| | The media roll is not loaded correctly. | Load the media roll correctly. |

14. Printer Specification

| Model | B-FP2D-GH30-QM-S | B-FP2D-GH50-QM-S |
|--|---|--|
| Media type | Label, Tag, Receipt, Linerless Label | |
| Print method | Direct thermal | |
| Resolution | 203dpi (8dots/mm) | |
| Print speed | Max 6 inches/s (152.4 mm/s) (It depends on the operating environment, print conditions, battery condition and etc.) | |
| Effective print width | 54 mm (2 inches) | |
| Issue mode | Batch, Peel-off | |
| Barcode | UPC-A/E, EAN8/13,UPC-A/E add on 2&5, EAN-8/13 add on 2&5, Code39, Code93, Code128, EAN128, NW7, MSI, Industrial 2 of 5, ITF, Postnet, RM4SCC, KIX-code, GS1 Databar | |
| Two dimensional code | Data Matrix, PDF417, Maxicode, QR code, Micro PDF417, Micro QR, GS1 Data Matrix, Aztec | |
| Font | Bitmap: Alphanumeric 25types, Simplified Chinese 24x24(GB18030), Japanese gothic 16x16, 24x24, Mincho 32x32 Outline: 5 types Open type font: Noto Hans Sans (CJK) | |
| LCD | TFT Color LCD, 128x128 dots with a backlight | |
| Battery | 7.2V 2500mAh (Nominal Capacity) Li-Ion battery | |
| Dimension | 97 (W) x 130 (D) x 69 (H) mm (Excluding the project parts) | |
| Weight (with a battery pack installed) | 462 g | 469 g |
| Operating temperature | -15°C to 40°C (5°F to 104°F) | |
| Operating humidity | 20~80% RH (No condensation) | |
| Charging temperature | AC adapter: 0°C to 40°C (32°F to 104°F) | |
| Memory | Flash ROM: 128 MB, SDRAM: 32 MB | |
| Interface | Bluetooth V2.1+EDR | Bluetooth V2.1+EDR Wireless LAN (IEEE802.11a/b/g/n) |
| | USB 2.0 connector: USB-TypeC | |
| NFC | ISO/IEC14443 Type A, NFC Forum Type 2, 144 bytes | |
| Media sensor | Label gap Black mark Paper end Peel-off | |
| Option | 1 slot battery charger (B-EP800-CHG-QM-R) 6 slot battery charger (B-EP800-CHG6-QM-R) AC adapter (B-FP800-AC-QM-S) 1 slot cradle charger (B-FP802-CR-QM-S) 4 slot cradle charger (B-FP802-CR4-QM-S) Shoulder strap (B-EP900-SS-QM-R) Spare battery pack (B-FP803-BTH-QM-R) Linerless Platen Kit (B-FP902-LL-QM-S) Carry Case (B-FP902-CC-QM-S) DC jack plug adapter (B-FP800-DCJA-QM-R) | |

15. Media Specification

<Labels>

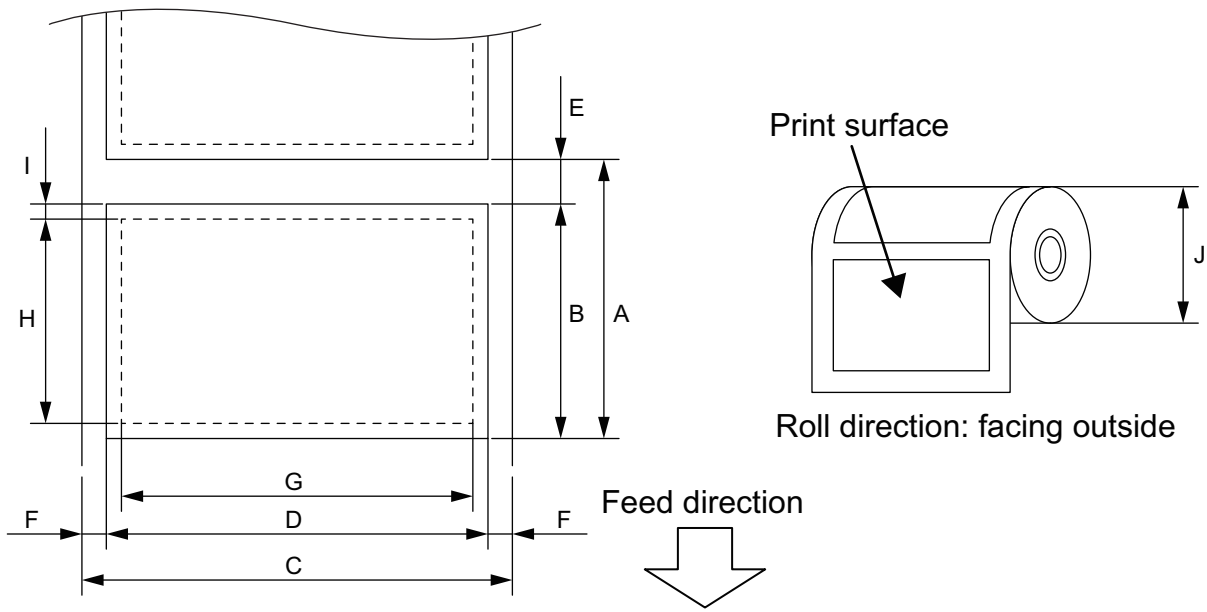

<Tags/Receipts>

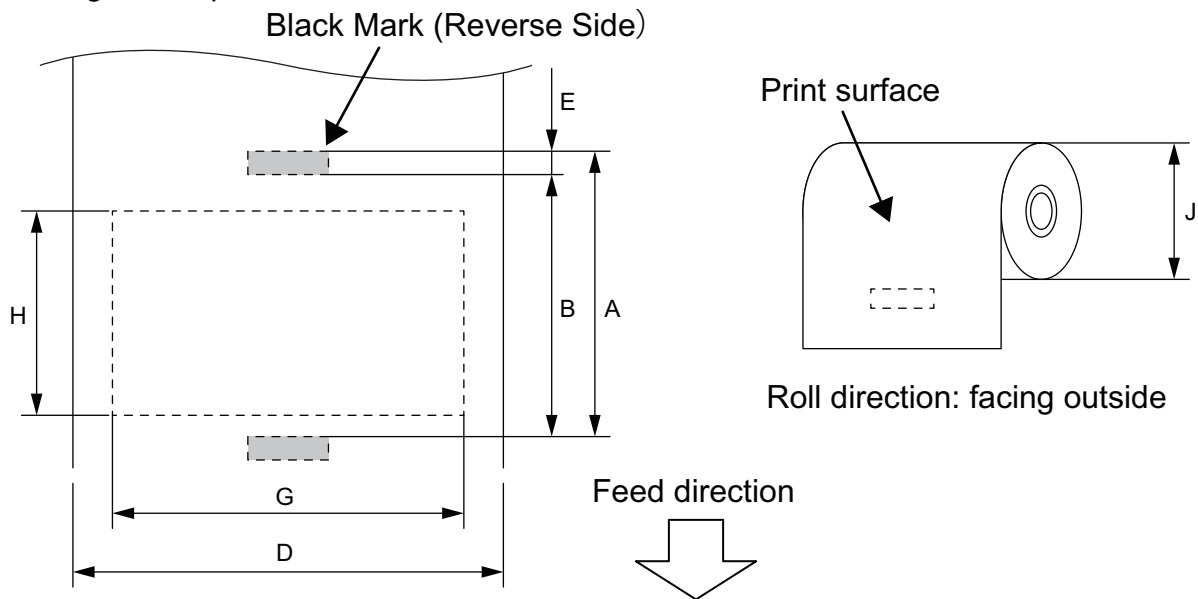

(Unit: mm)

| Item | Media type | Label | | Receipt | | Linerless ^{*1} | | |
|------|------------------------|-------|-------------------------------------|------------------|---------------------|-------------------------|--|---|
| | Mode | Batch | Strip | With black marks | Without black marks | | | |
| A | Label pitch | Min. | 10.0 | 13.0 | 10.0 | 10.0 | 16.0 | |
| | | Max. | 999.9 | 67.0 | 999.9 | - | - | |
| B | Label length | Min. | 7.0 | 10.0 | 7.0 | - | - | |
| | | Max. | 996.9 | 60.0 | 996.9 | - | - | |
| C | Backing paper width | Min. | 26.0 | | - | | - | |
| | | Max. | 58.0 | | - | | - | |
| D | Label width | Min. | 24.0 | | - | | - | |
| | | Max. | 58.0 | | - | | - | |
| D | Media width | Min. | - | | 24.0 | | 32.0 | |
| | | Max. | - | | 58.0 | | 58.0 | |
| E | Label-to-label gap | Min. | 3.0 | | - | | - | |
| | | Max. | 7.0 | | - | | - | |
| E | Black mark length | Min. | 3.0 | | | - | | - |
| | | Max. | 7.0 | | | - | | - |
| F | Vertical gap width | Min. | 1.0 | | - | | - | |
| | | Max. | 7.0 | | - | | - | |
| G | Effective print width | Max. | 54.0 | | | | | |
| H | Effective print length | Max. | 995.0 | 58.0 | 995.0 | - | - | |
| I | Unprintable area | | 1.0 from the upper/lower label edge | | | - | 6.5 from the upper label edge 1.0 from the lower label edge | |
| J | Outer roll diameter | Max. | φ60.0 | | | | | |
| | Roll direction | | Outside only | | | | | |

*1 A linerless Platen Kit (Option:B-FP902-LL-QM-S) is required to use linerless media. When using linerless media, please contact your local distributor for consultation.

16. Care/Handling of the Media Roll

CAUTION!

Be sure to read carefully and understand the Supply Manual. Use only media that meet the specified requirements. The use of non-specified media may shorten the head life and result in problems with bar code readability or print quality. All media rolls should be handled with care to avoid any damage to the media rolls or printer. Read the following guideline carefully.

- Do not store the media rolls for longer than the manufacturer's recommended shelf life.
- Store media rolls on the flat end. Do not store them on the curved sides. This may flatten that side causing an erratic media advance and poor print quality.
- Store the media rolls in plastic bags and always reseal after opening. Unprotected media rolls can get dirty and the extra abrasion from the dust and dirt particles will shorten the print head life.
- Store the media rolls in a cool, dry place. Avoid areas where they would be exposed to direct sunlight, high temperature, high humidity, dust or gas.
- The thermal paper used for direct thermal printing must not have specifications which exceed Ca^{++} 800 ppm, Na^+ 800 ppm, K^+ 800 ppm and Cl^- 600 ppm.
- Some ink used on pre-printed labels may contain components which shorten the print head's product life. Do not use labels pre-printed with ink which contains hard substances such as carbonic calcium (CaCO_3) and kaolin (Al_2O_3 , 2SiO_2 , $2\text{H}_2\text{O}$).

For further information, contact your local distributor or your media roll manufacturer.

Portable Printer
Owner's Manual
B-FP2D-GH30-QM-S
B-FP2D-GH50-QM-S

Toshiba Tec Corporation

1-11-1, OSAKI, SHINAGAWA-KU, TOKYO, 141-8562, JAPAN

© 2019-2022 Toshiba Tec Corporation All rights reserved

PRINTED IN INDONESIA
Ver04 F BU21000400-EN