

# TOSHIBA

Note : This document has been translated from the Japanese original for reference purposes only. In the event of any discrepancy between this translated document and the Japanese original, the original shall prevail.

## FY2025 Consolidated Business Results

Toshiba Tec Corporation  
May 11, 2026

Toshiba Tec Group Philosophy  
**Creating with You**

# Contents

**01 Key Messages**

**02 FY2025 Consolidated Business Results**

**03 FY2026 Forecast**

# 01

## Key Messages

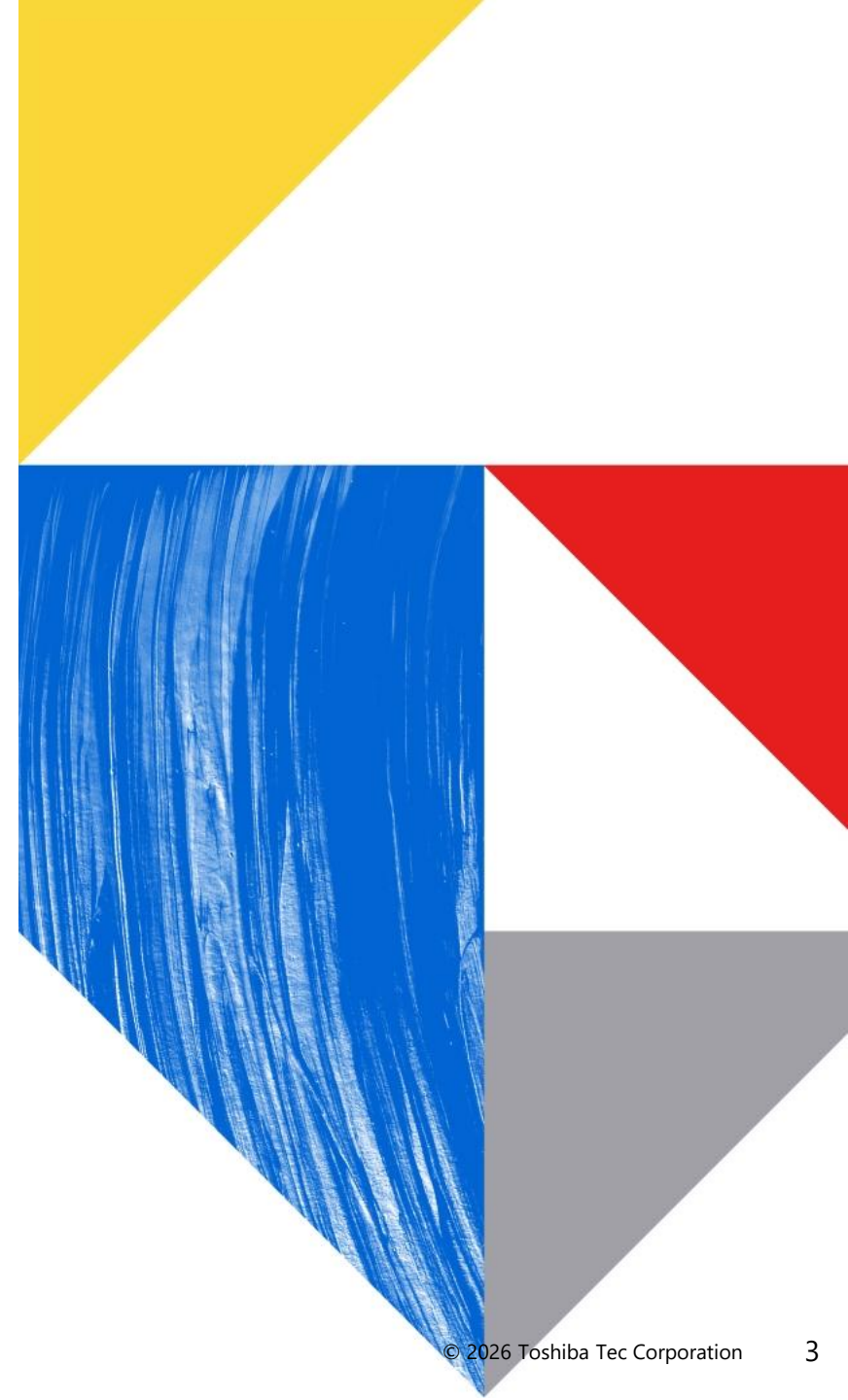

# Key Messages

## FY2025 Business Results

- Operating profit for FY2025 amounted to 14.3 billion yen a decrease of 5.9 billion yen year-on-year. Despite the impact of US tariffs amounting to  $\Delta$ 11.4 billion yen, profitability improved quarter by quarter as tariff measures progressed, leading to a steady recovery. Operating profit for the fourth quarter of FY2025 (Jan-Mar) reached 11.8 billion yen.
- While the overseas retail business and the workplace business deteriorated due to the impact of tariffs, operating profit of the domestic retail business reached 11.5 billion yen (+40% year-on-year).
- Although net profit for the year resulted in a loss due to a loss on valuation of investment securities and other factors, the planned recovery from the impact of tariffs progressed in the second half, leading to an improvement in operating profit; accordingly, year-end dividends of 20 yen will be paid as planned.

## Toward the Next Stage as a Solutions Company

- Transitioning from a hardware-centric business model to a recurring solutions business focused on addressing customer challenges.
- Expanding customers, partners, and services with ELERA as the platform; deployed by 13 of the world top retailers / in more than 30 countries.
- Solutions sales in the workplace business increased by 4% on a local currency basis.

## FY2026 Forecast

- Operating profit for FY2026 is increase by 5.7 billion yen year-on-year to 20.0 billion yen
  - Domestic retail business: Introduction of major contracts is expected to enter a full-scale phase
  - Overseas retail business: Demand is gradually recovering
  - Workplace business: The effect of price revisions becomes evidentHowever, certain impacts from rising prices of semiconductors, oil, and other components are factored in.
- Temporary expenses are planned to be recorded as an extraordinary loss in order to improve the management foundation.

# 02

## **FY2025 Consolidated Business Results**

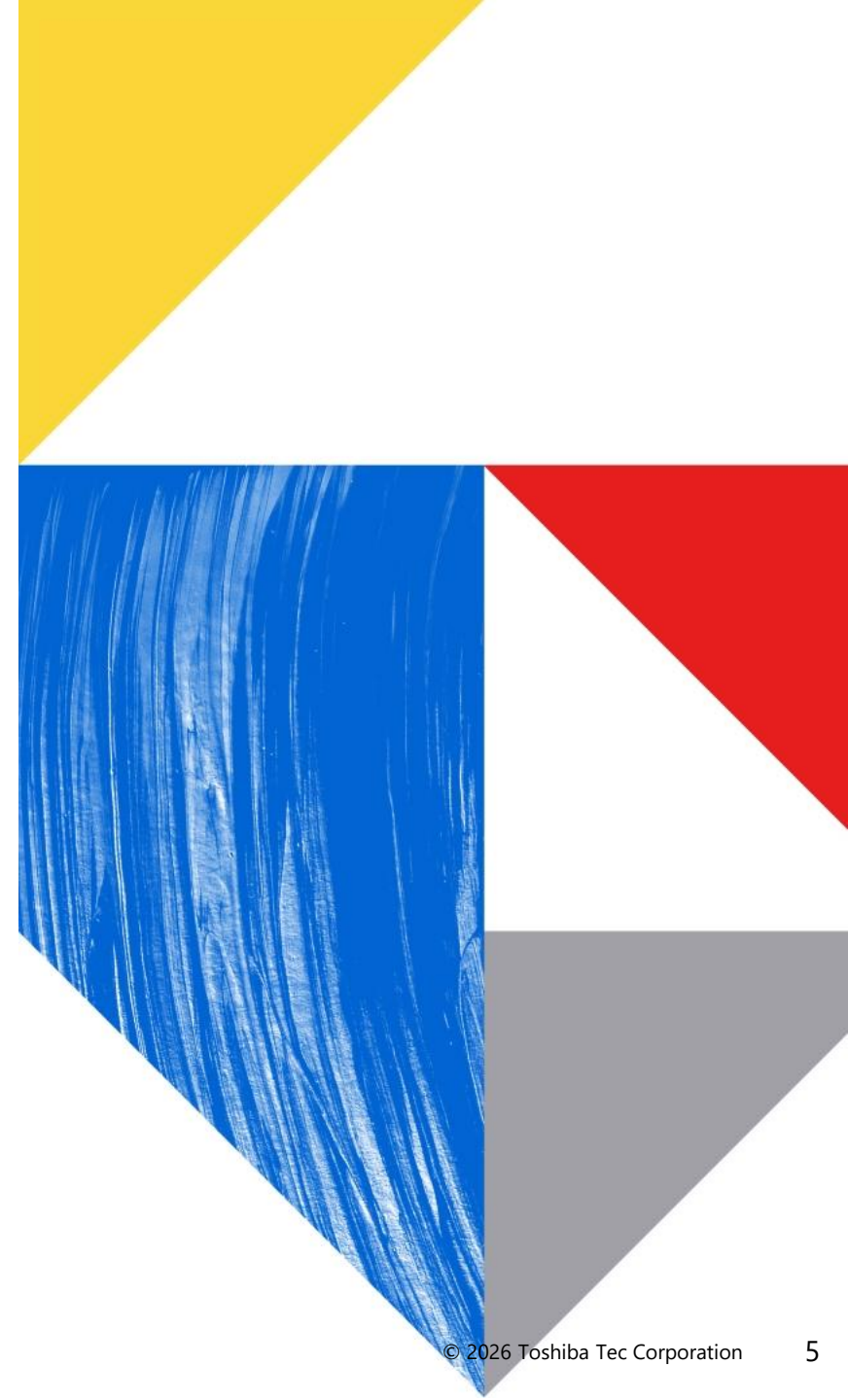

# FY2025/4Q Business Results (Consolidated)

(Billions of yen)

	FY2025/4Q	FY2025/4Q	FY2024/4Q	Difference	
	Actual	Forecast announced on Feb 9	Actual	vs Forecast announced on Feb 9	vs FY2024/4Q
<b>Net Sales</b>	<b>169.4</b>	<b>170.2</b>	<b>151.5</b>	<b>△0.7</b>	<b>+17.9</b>
<b>Operating Profit</b> (Rate of sales)	<b>11.8</b> <b>(7.0%)</b>	<b>9.5</b> <b>(5.6%)</b>	<b>8.5</b> <b>(5.6%)</b>	<b>+2.3</b>	<b>+3.3</b>
<b>Ordinary Profit</b> (Rate of sales)	<b>10.2</b> <b>(6.0%)</b>	<b>7.6</b> <b>(4.4%)</b>	<b>7.2</b> <b>(4.7%)</b>	<b>+2.6</b>	<b>+3.0</b>
<b>Profit Attributable to Owners of Parent</b> (Rate of sales)	<b>6.5</b> <b>(3.9%)</b>	<b>8.8</b> <b>(5.2%)</b>	<b>2.8</b> <b>(1.8%)</b>	<b>△2.3</b>	<b>+3.8</b>

# FY2025 Business Results (Consolidated)

(Billions of yen)

	FY2025 Actual	FY2025 Forecast announced on Feb 9	FY2024 Actual	Difference	
				vs Forecast announced on Feb 9	vs FY2024
<b>Net Sales</b>	<b>569.3</b>	<b>570.0</b>	<b>577.0</b>	<b>△0.7</b>	<b>△7.8</b>
<b>Operating Profit</b> (Rate of sales)	<b>14.3</b> (2.5%)	<b>12.0</b> (2.1%)	<b>20.3</b> (3.5%)	<b>+2.3</b>	<b>△5.9</b>
<b>Ordinary Profit</b> (Rate of sales)	<b>10.6</b> (1.9%)	<b>8.0</b> (1.4%)	<b>18.3</b> (3.2%)	<b>+2.6</b>	<b>△7.7</b>
<b>Profit/Loss Attributable to Owners of Parent</b> (Rate of sales)	<b>△2.3</b> (-%)	<b>0.0</b> (0.0%)	<b>29.9</b> (5.2%)	<b>△2.3</b>	<b>△32.2</b>
<b>Dividends</b>	<b>20Yen</b>	<b>20Yen</b>	<b>45Yen</b>	<b>-</b>	<b>△25Yen</b>
<b>Foreign Currency Exchange Rate (Yen)</b>	<b>150.22</b>	<b>149.44</b>	<b>152.73</b>	<b>+0.78</b>	<b>△2.51</b>
US\$	<b>173.77</b>	<b>172.38</b>	<b>163.77</b>	<b>+1.39</b>	<b>+10.00</b>
EUR					

# Operating Profit Analysis of FY2025

(Billions of yen)

## The chart of profit transition

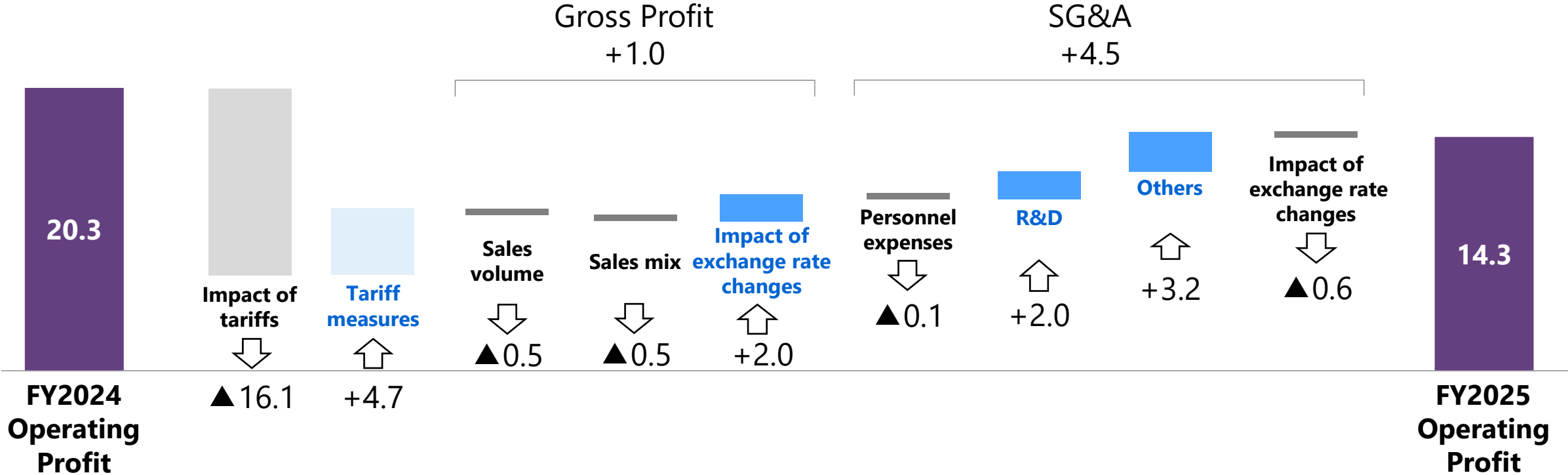

# FY2025 Business Results (Quarterly)

(Billions of yen)

## Quarterly net sales and operating profit

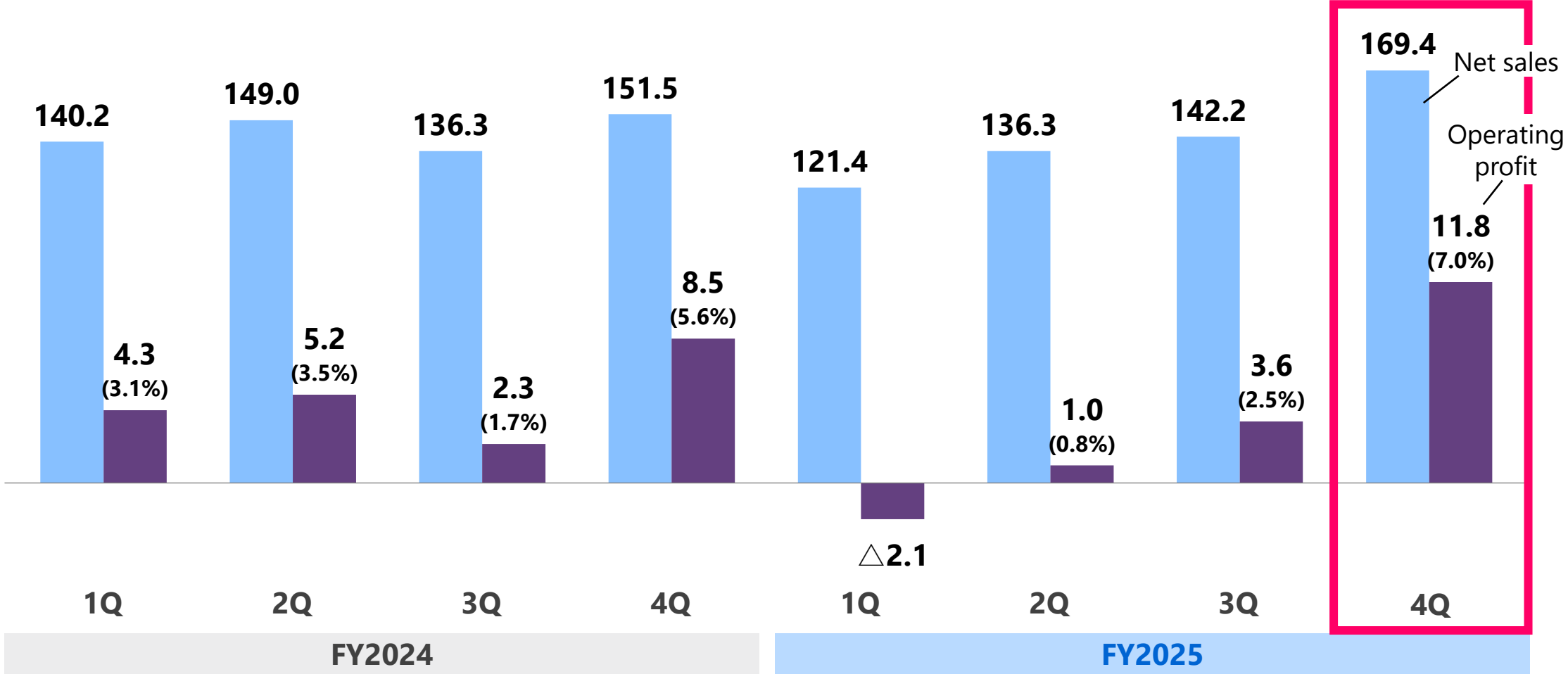

# FY2025 Business Results by Segment

(Billions of yen)

## Retail Solutions Business Group

	FY2025 Actual	FY2025 Forecast announced on Feb 9	FY2024 <sup>(*1)</sup> Actual	Difference	
				vs Forecast announced on Feb 9	vs FY2024
<b>Net Sales</b>	<b>347.6</b>	<b>352.0</b>	<b>346.7</b>	<b>△4.4</b>	<b>+0.9</b>
<b>Operating Profit</b> 【Domestic / Overseas】 (Rate of sales)	<b>7.6</b> 【11.5 / △3.9】 (2.2%)	<b>7.0</b> 【11.0 / △4.0】 (2.0%)	<b>7.9</b> 【8.2 / △0.3】 (2.3%)	<b>+0.6</b>	<b>△0.3</b>

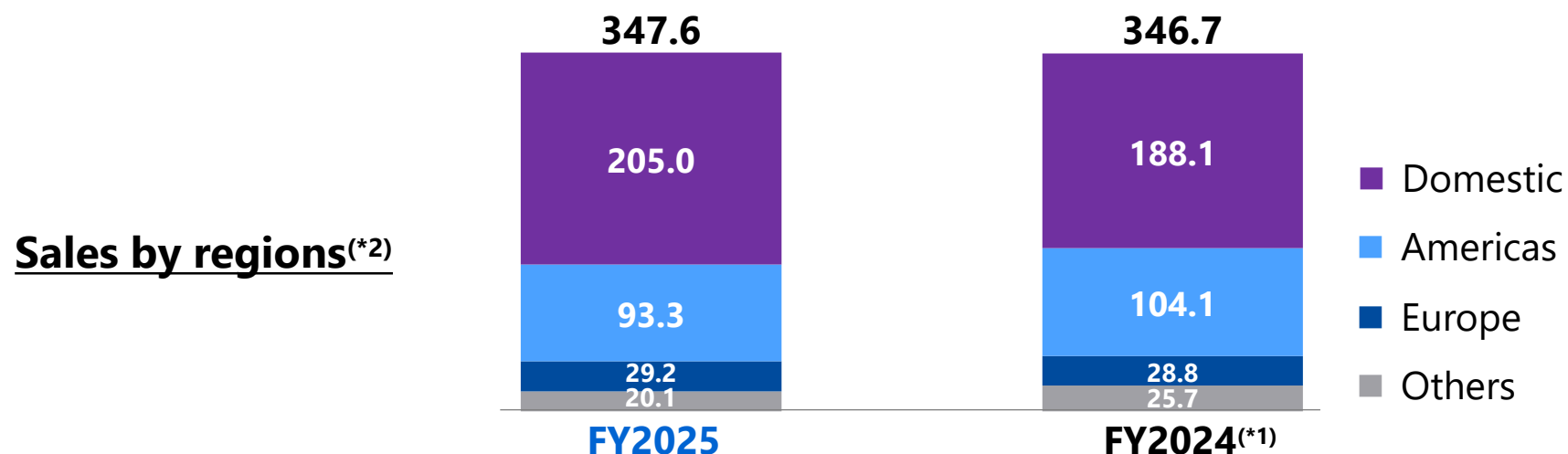

(\*1) The business related to MFP for the domestic market, which was included in the Workplace Solutions Business Group until FY2024, has been transferred to the Retail Solutions Business Group from FY2025. Therefore, the actual results for FY2024 are shown as the amount after segment reclassification.

(\*2) Calculated based on the location of the sales base

# FY2025 Business Results by Segment (Quarterly)

(Billions of yen)

## Retail Solutions Business Group

### Quarterly net sales and operating profit

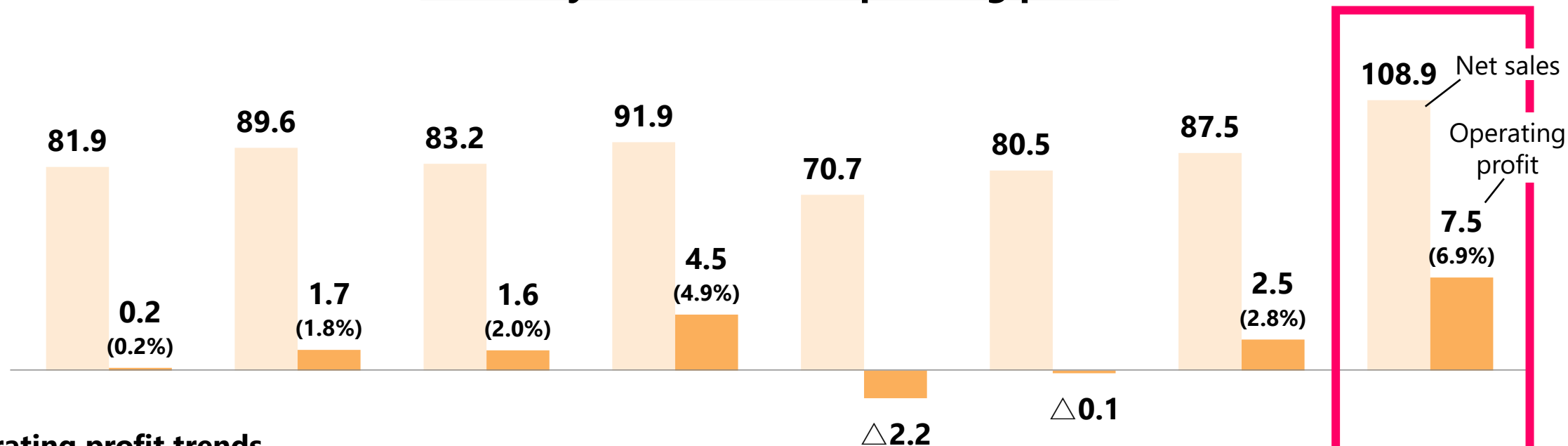

### Operating profit trends

Domestic	1.3	1.9	2.1	2.8	1.4	2.2	3.5	4.4
Overseas	△1.2	△0.2	△0.5	1.7	△3.6	△2.3	△1.0	3.1
	1Q	2Q	3Q	4Q	1Q	2Q	3Q	4Q
	FY2024(*)				FY2025			

(\*) The business related to MFP for the domestic market, which was included in the Workplace Solutions Business Group until FY2024, has been transferred to the Retail Solutions Business Group from FY2025. Therefore, the actual results for FY2024 are shown as the amount after segment reclassification.

# FY2025 Business Results by Segment

(Billions of yen)

## Workplace Solutions Business Group

	FY2025 Actual	FY2025 Forecast announced on Feb 9	FY2024 <sup>(*1)</sup> Actual	Difference	
				vs Forecast announced on Feb 9	vs FY2024
<b>Net Sales</b>	<b>227.8</b>	<b>225.0</b>	<b>237.4</b>	<b>+2.8</b>	<b>△ 9.6</b>
<b>Operating Profit</b> (Rate of sales)	<b>6.7</b> (2.9%)	<b>5.0</b> (2.2%)	<b>12.3</b> (5.2%)	<b>+1.7</b>	<b>△ 5.6</b>

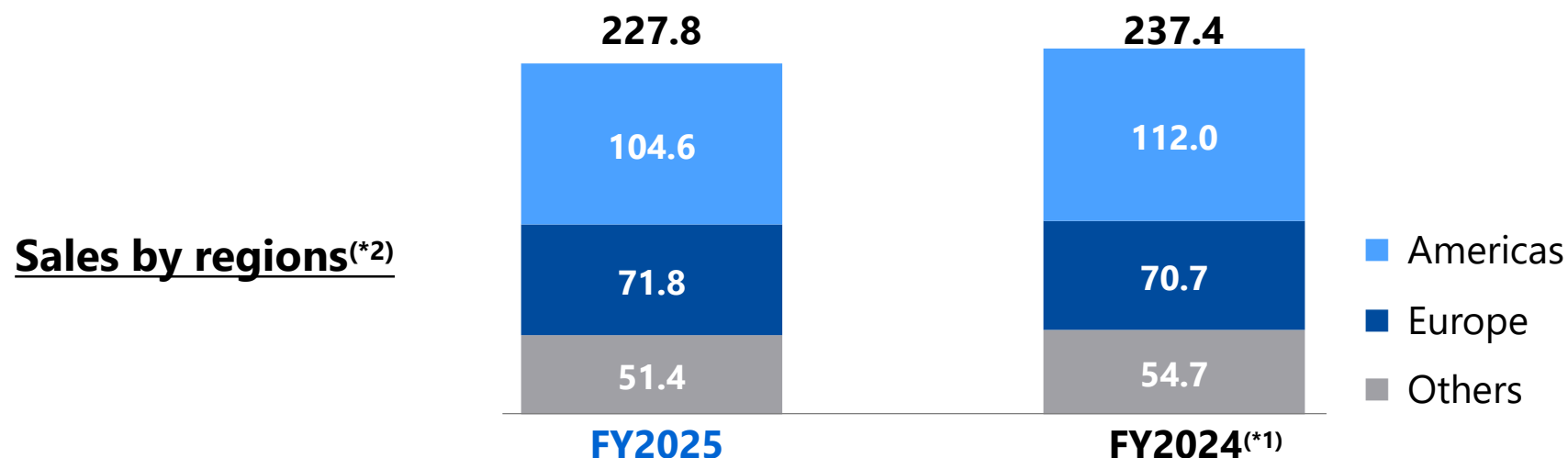

(\*1) The business related to MFP for the domestic market, which was included in the Workplace Solutions Business Group until FY2024, has been transferred to the Retail Solutions Business Group from FY2025. Therefore, the actual results for FY2024 are shown as the amount after segment reclassification.

(\*2) Calculated based on the location of the sales base

# FY2025 Forecast by Segment (Quarterly)

(Billions of yen)

## Workplace Solutions Business Group

### Quarterly net sales and operating profit

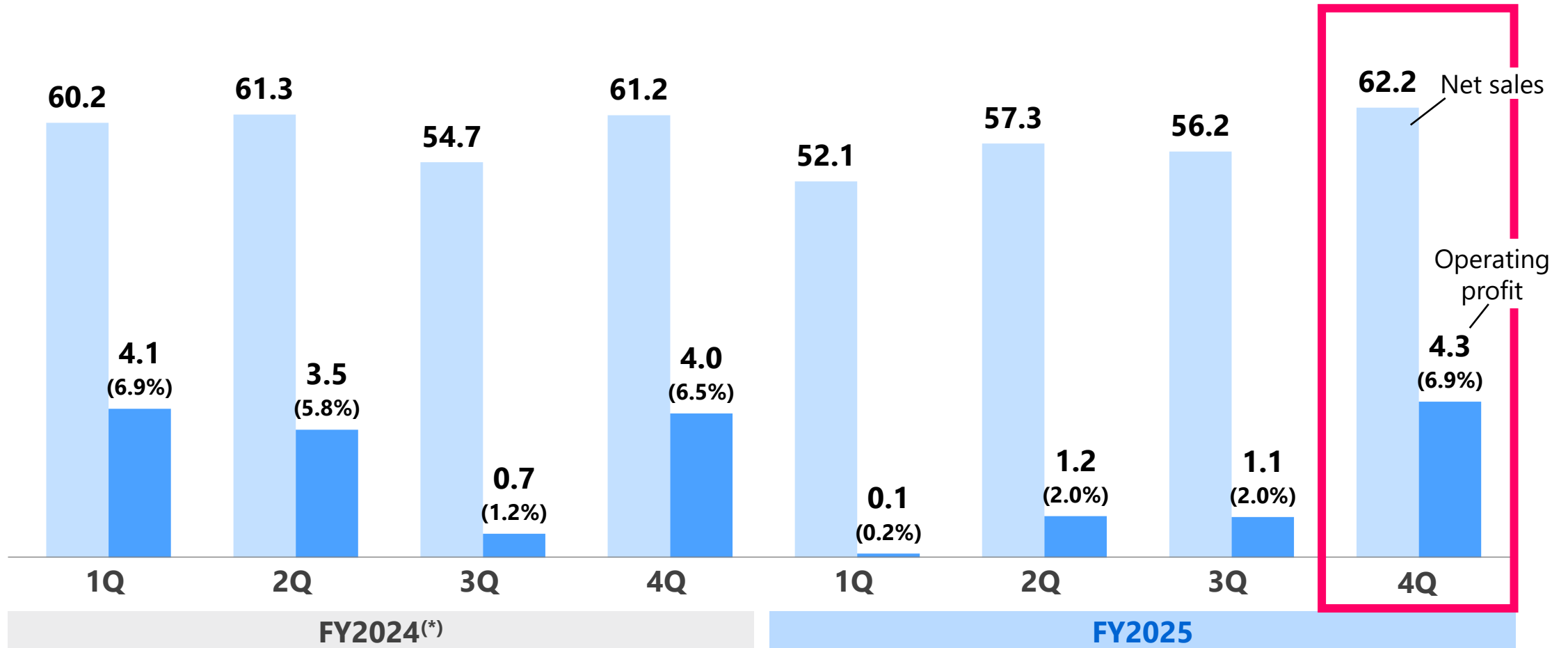

(\*) The business related to MFP for the domestic market, which was included in the Workplace Solutions Business Group until FY2024, has been transferred to the Retail Solutions Business Group from FY2025. Therefore, the actual results for FY2024 are shown as the amount after segment reclassification.

# Balance Sheet

(Billions of yen)

## Assets

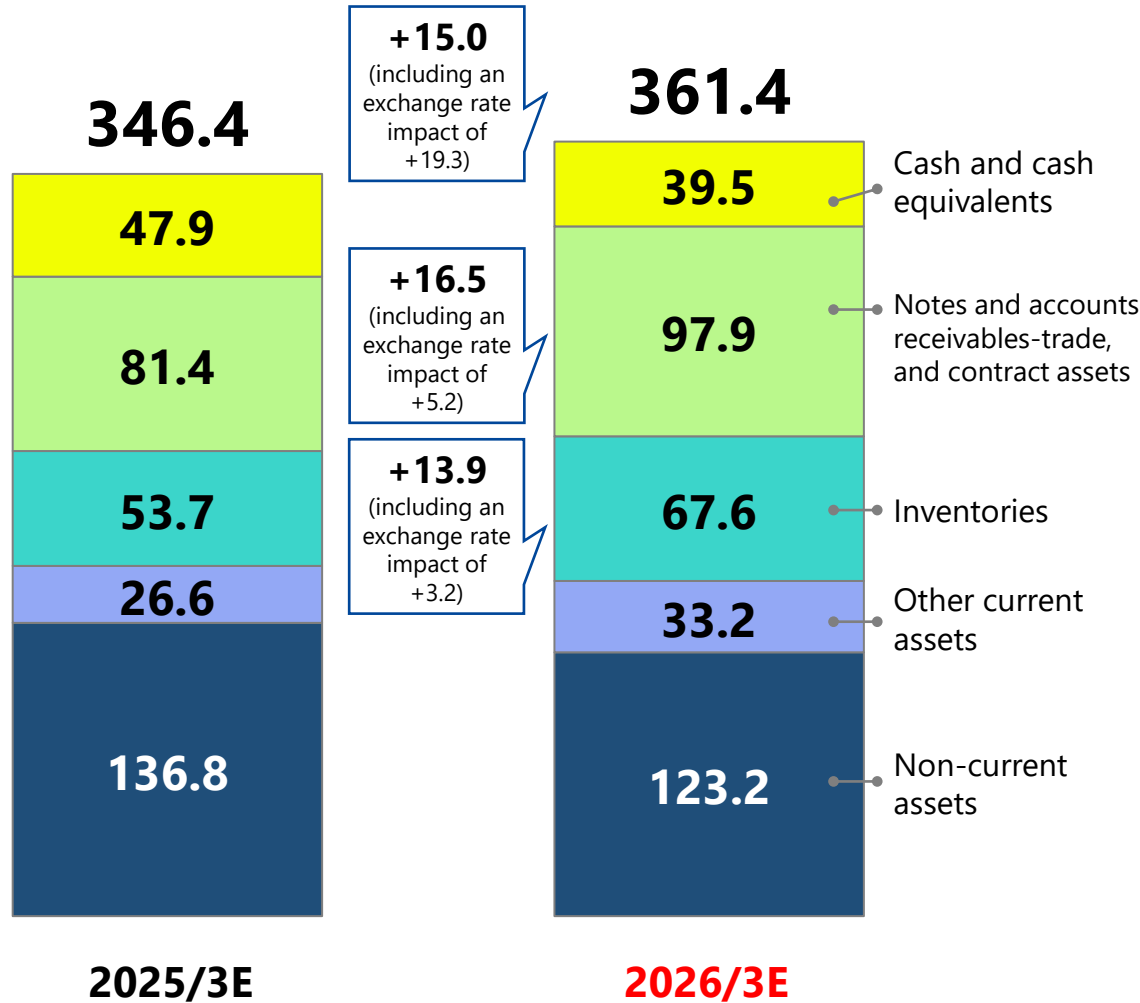

## Liabilities and Net Assets

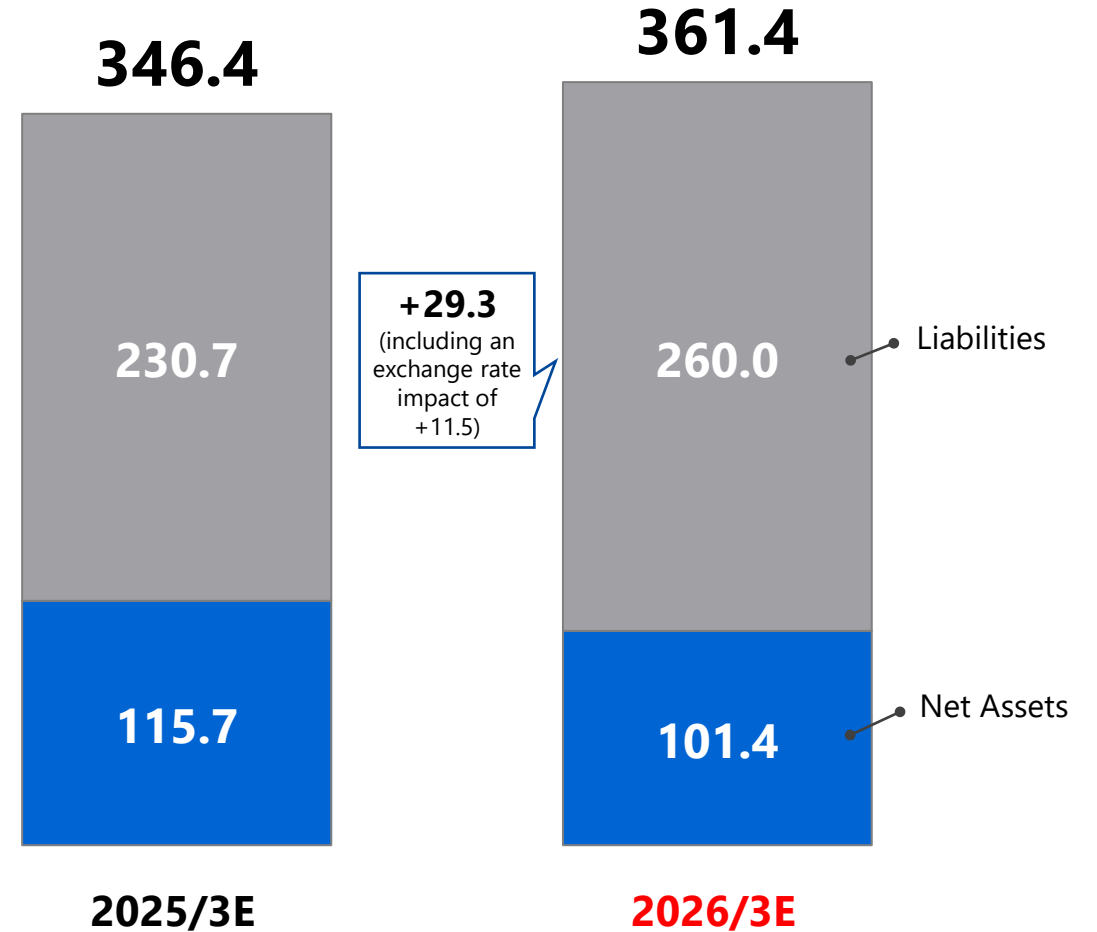

# FY2025 Cash Flows

(Billions of yen)

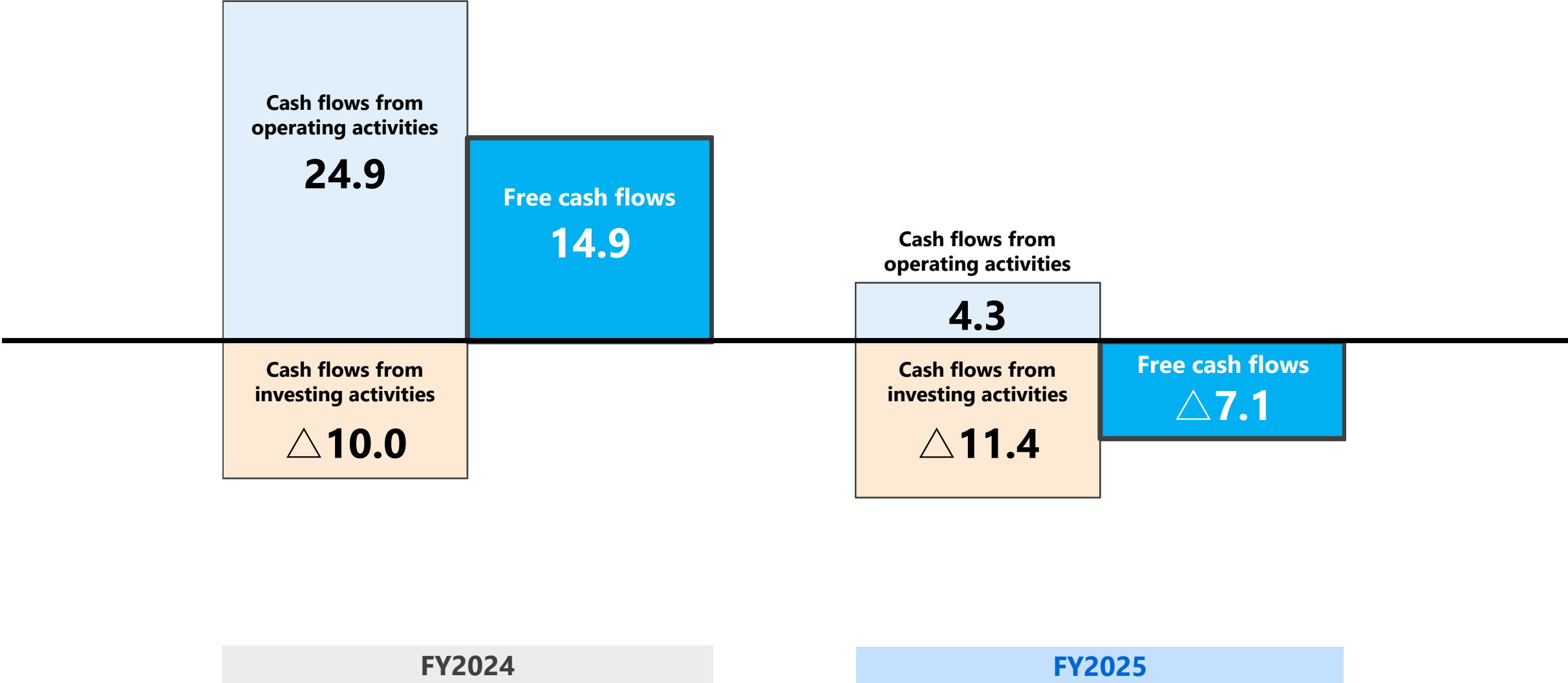

# 03

## **FY2026 Forecast**

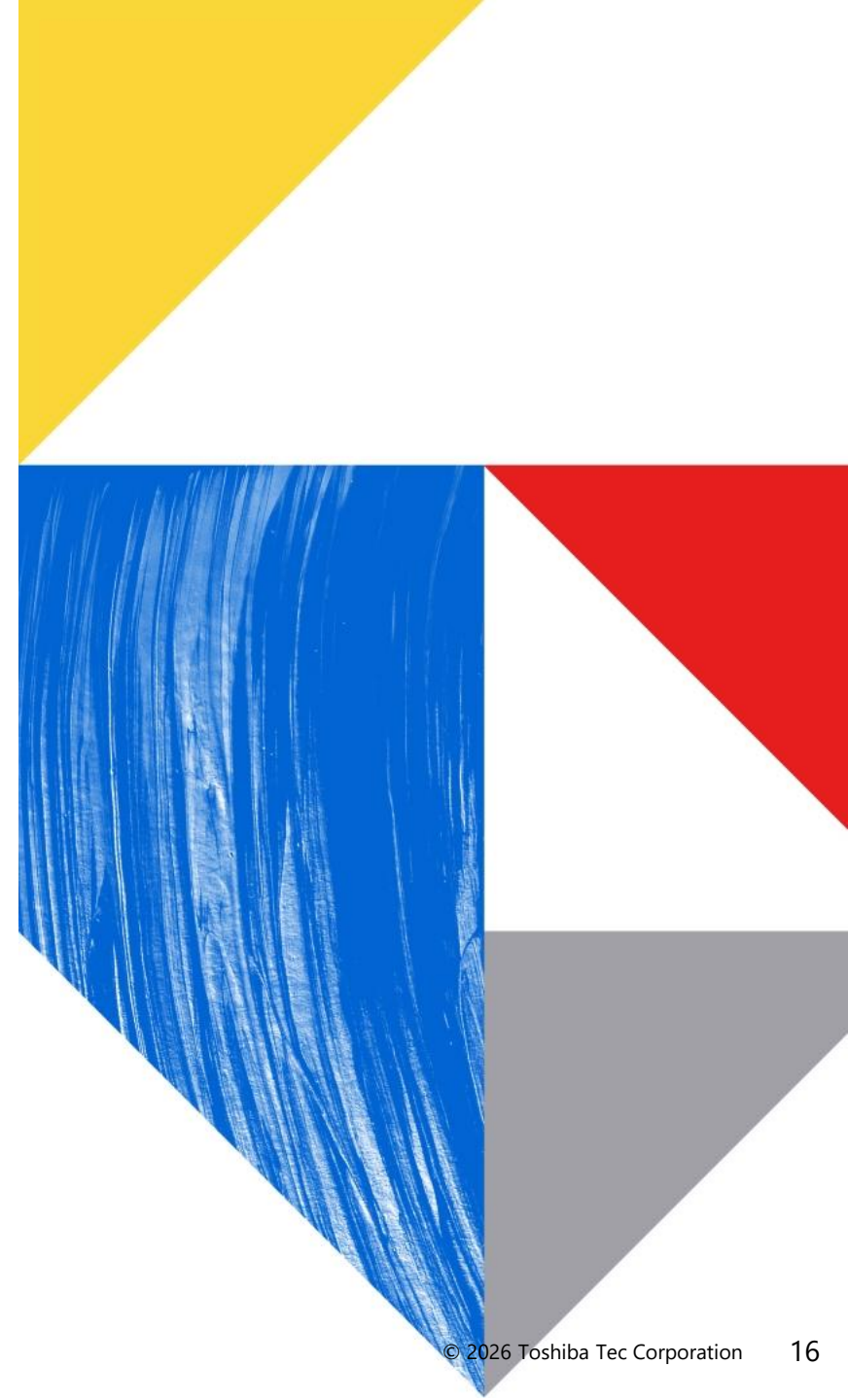

# FY2026 Forecast (Consolidated)

(Billions of yen)

		<b>FY2026</b> Forecast	<b>FY2025</b> Actual	<b>Difference</b> vs FY2025
<b>Net Sales</b>		<b>590.0</b>	<b>569.3</b>	<b>+20.7</b>
<b>Operating Profit</b>		<b>20.0</b>	<b>14.3</b>	<b>+5.7</b>
	(Rate of sales)	(3.4%)	(2.5%)	
<b>Ordinary Profit</b>		<b>16.0</b>	<b>10.6</b>	<b>+5.4</b>
	(Rate of sales)	(2.7%)	(1.9%)	
<b>Profit/Loss Attributable to Owners of Parent</b>		<b>7.0</b>	<b>△ 2.3</b>	<b>+9.3</b>
	(Rate of sales)	(1.2%)	(-%)	
<b>Dividends</b>		<b>40Yen</b>	<b>20Yen</b>	<b>+20Yen</b>
<b>Foreign Currency Exchange Rate (Yen)</b>	<b>US\$</b>	<b>150.00</b>	<b>150.22</b>	<b>△ 0.22</b>
	<b>EUR</b>	<b>175.00</b>	<b>173.77</b>	<b>+1.23</b>

# Investment to improve the management foundation

① **Optimization of the cost structure**  
(streamlining, efficiency improvements, and a shift toward a more variable cost base)



② **Lowering the break-even point and strengthening the ability to respond to rapid changes in the business environment**



③ **Improving the management foundation in addition to investments in growth businesses**  
(through temporary expenses and capital investment)

[Key initiatives]

- **Improvement** of profitability by region
- **Reduction** of indirect operations
- **Asset-light initiatives**

[Execution measures]

- **Review** of operational sites
- **Enhancement** of IT infrastructure
- **Expansion** of AI / IT utilization
- **Utilization of external resources** such as BPO

# FY2026 Forecast by Segment

(Billions of yen)

## Retail Solutions Business Group

	FY2026 Forecast	FY2025 Actual	Difference vs FY2025
<b>Net Sales</b> 【Domestic / Overseas】	<b>372.0</b> 【218.0 / 154.0】	<b>347.6</b> 【205.0 / 142.7】	<b>+24.4</b>
<b>Operating Profit</b> 【Domestic / Overseas】 (Rate of sales)	<b>13.0</b> 【12.5 / 0.5】 (3.5%)	<b>7.6</b> 【11.5 / △3.9】 (2.2%)	<b>+5.4</b>

### Domestic Retail Solutions

Introduction of major contracts is expected to enter a full-scale phase

### Overseas Retail Solutions

Although investment appetite, which had been depressed due to the impact of US tariffs, is showing signs of recovery and demand is gradually improving, uncertainty in the demand environment is factored in

# FY2026 Forecast by Segment

(Billions of yen)

## Workplace Solutions Business Group

	<b>FY2026 Forecast</b>	<b>FY2025 Actual</b>	<b>Difference vs FY2025</b>
<b>Net Sales</b>	<b>227.0</b>	<b>227.8</b>	<b>△0.8</b>
<b>Operating Profit</b> (Rate of sales)	<b>7.0</b> (3.1%)	<b>6.7</b> (2.9%)	<b>+0.3</b>

## Workplace Solutions

While the effects of price revisions and other measures to offset the direct impact of US tariffs become evident, uncertainty in the demand environment is factored in

# Operating Profit Analysis of FY2026 (vs FY2025)

(Billions of yen)

## The chart of profit transition

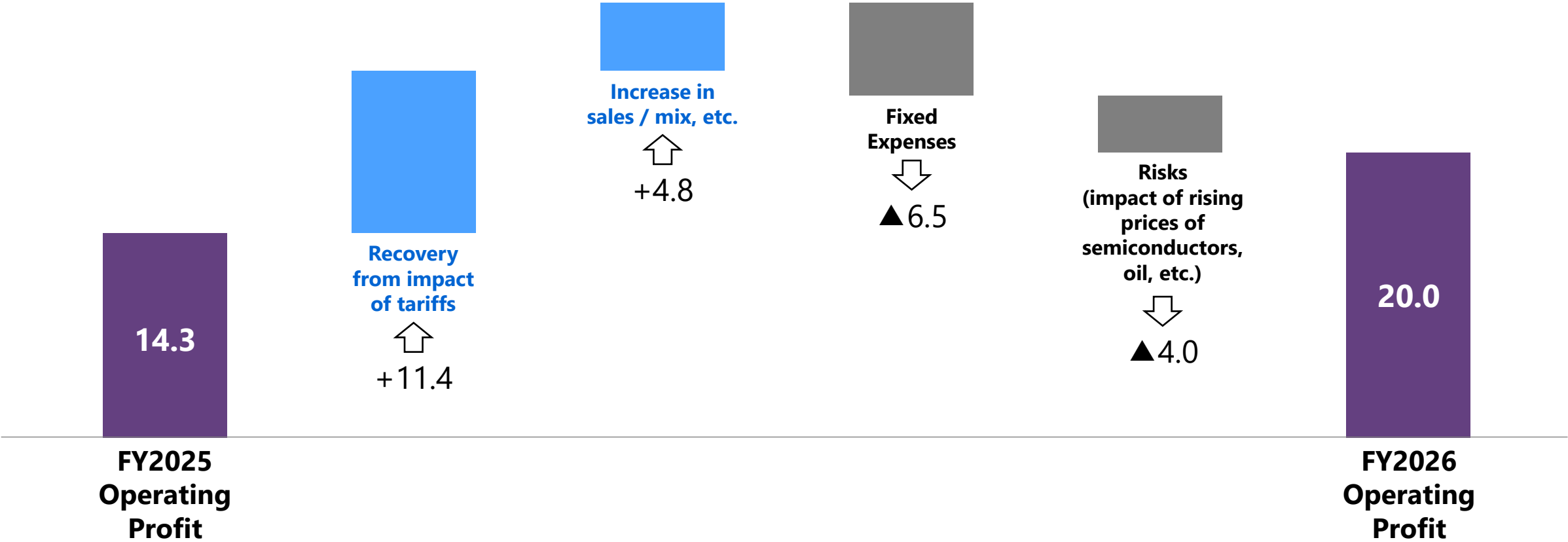

# Status of Growth Business Initiatives (Domestic Retail Business)

ELERA domestic sales has expanded by approx. 230 companies and 1,600 stores since last year  
 Leveraging a market share exceeding 50%, we will transition from a hardware / maintenance-centric business to a solutions company (physical + cyber)

## Domestic ELERA®

- Expanding in both # of ELERA contracted companies and stores
- ELERA collaboration partners are increasing

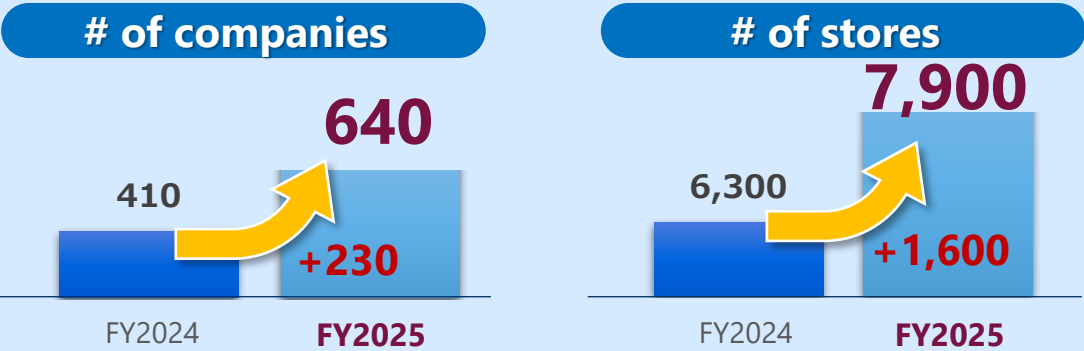

Recurring sales ratio : Actual / Plan<sup>(\*1)</sup>

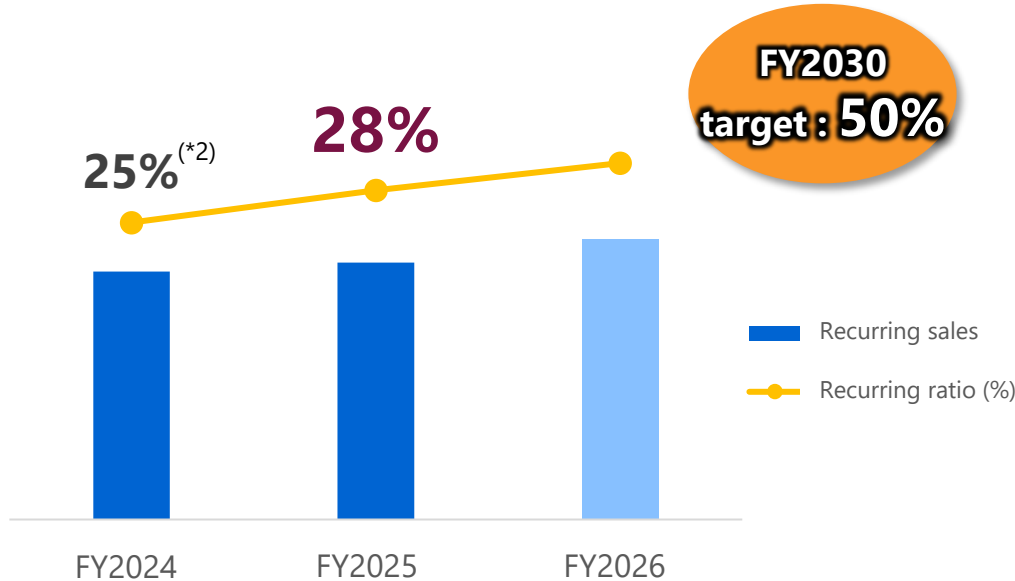

(\*1) The recurring sales and ratio above exclude major contracts  
 (\*2) Domestic MFP sales are excluded for FY2024 due to the figures being prior to the segment reclassification

# Status of Growth Business Initiatives (Overseas Retail Business)

**ELERA has gained high market recognition, with sales showing steady performance**

## Evaluation of ELERA®

- Highly rated by IDC as a **"Super Platform"**
- Recognized as a **Leading Industry Player** in the latest survey by IHL
- Received the VIP award in the **"Best Multi-Vendor Commerce Platform"** category at NRF 2026

## ELERA® Deployment Growth

- Deployed by **13 of the world top retailers** / in **more than 30 countries**
- Among the top 10 U.S. retailers, **7 are our customers**, and **4 have implemented ELERA®**
- Annual transactions worth **8 billion**
- Expecting to implement **more than 15,000 stores / 123,000 lanes** in total by FY2029
- Partner network is growing **"Toshiba Commerce Marketplace"**
  - Offers **over 990 APIs** and **69 microservices**

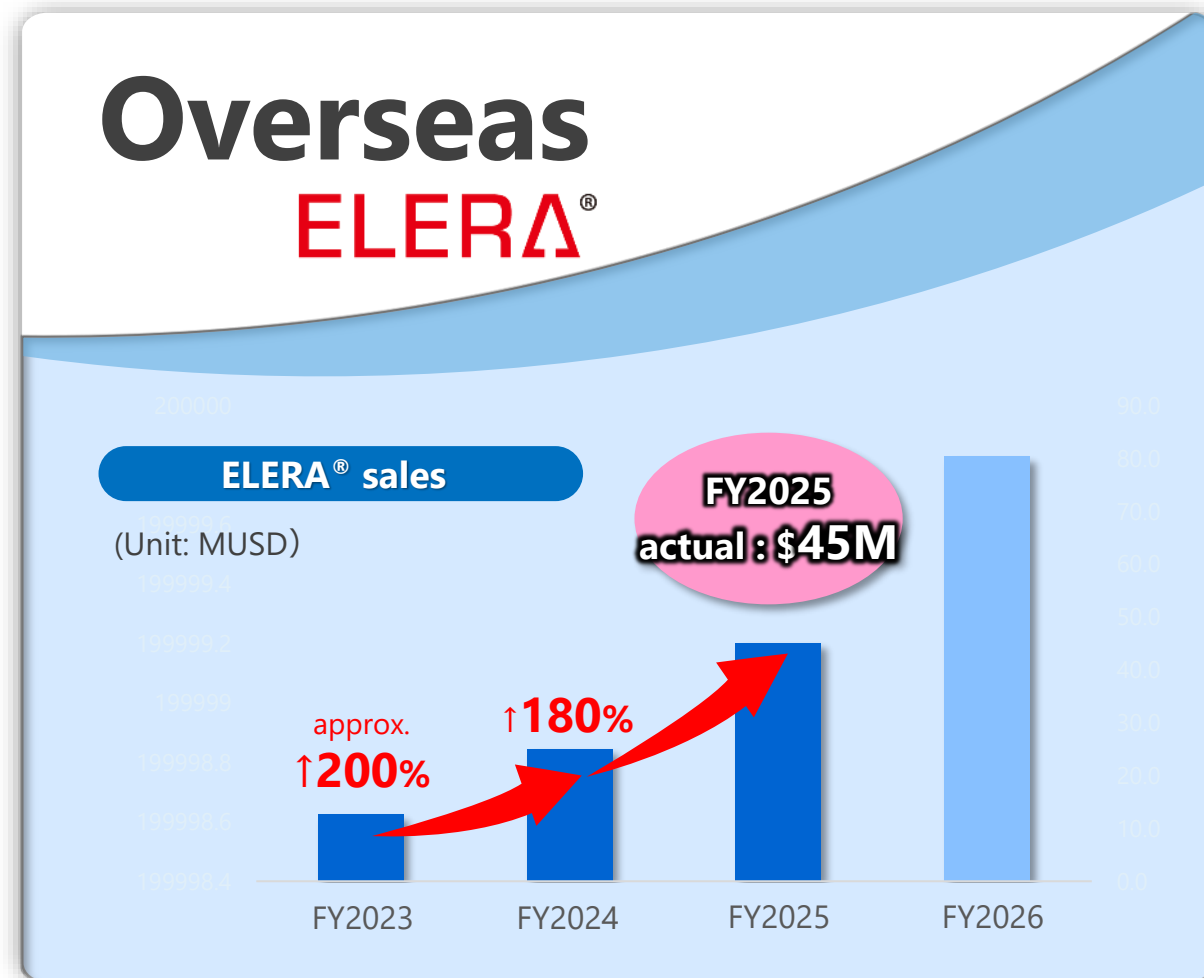

# Status of Growth Business Initiatives (Workplace Business)

**Solutions sales increased by 4% on a local currency basis  
Accelerating the transformation of the business**

## Expansion of Workplace Solutions

- [Solutions sales] (FY2025)
- Solutions sales grew 4% year-on-year (on a local currency basis)
  - DMS, cloud-linked solutions, and Auto-ID solutions served as key growth drivers

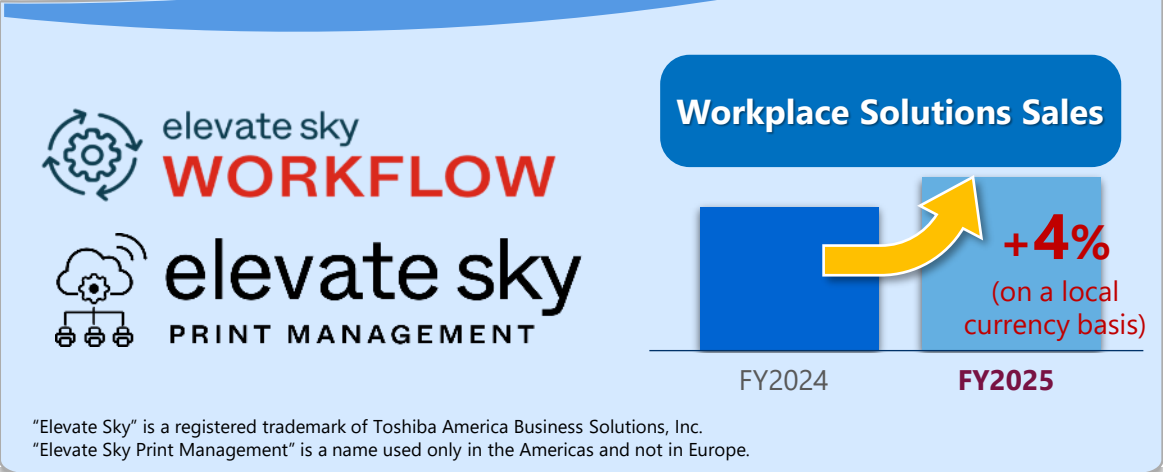

"Elevate Sky" is a registered trademark of Toshiba America Business Solutions, Inc.  
"Elevate Sky Print Management" is a name used only in the Americas and not in Europe.

## Expansion of solution offerings (strengthening partnerships and expanding our own offerings)

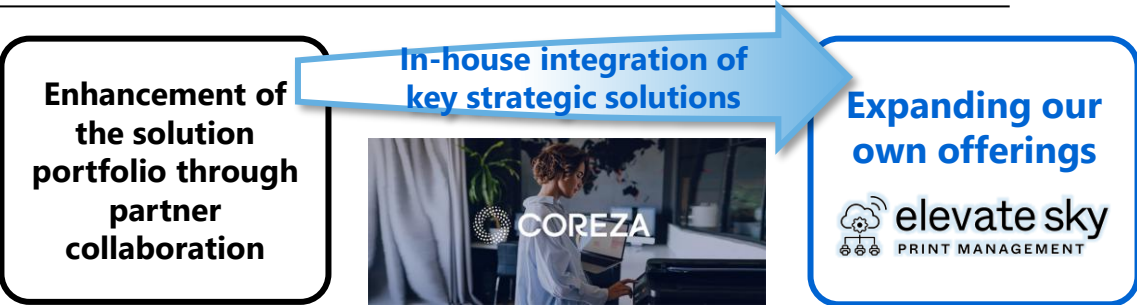

## Expansion of ETRIA

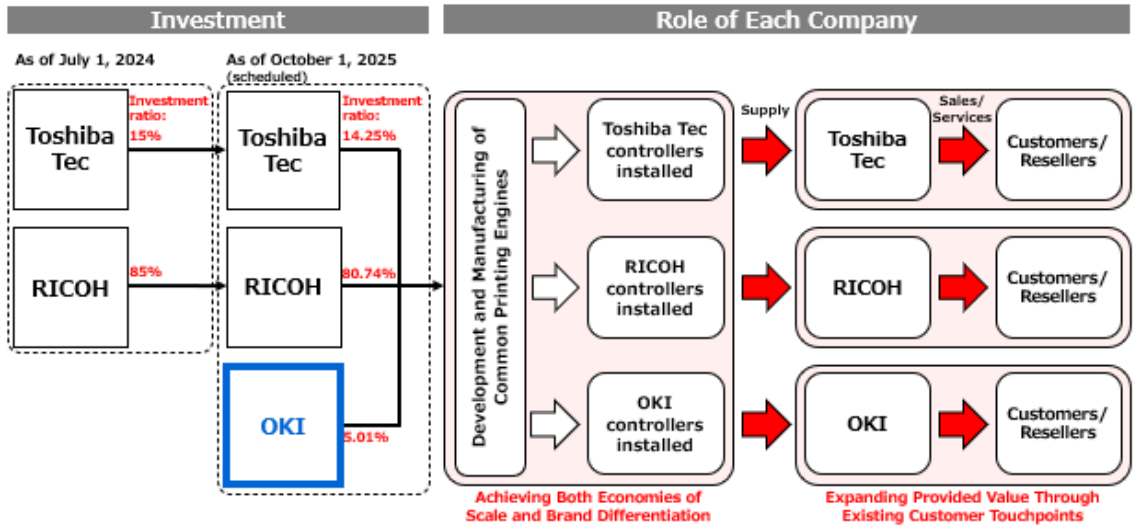

## FY2026 Management Policy Briefing

Date and Time : May 29, 2026 (Fri), 17:30 – 18:30

# Appendix

# FY2025 Business Results (Sales by Category)

(Billions of yen)

## Retail Solutions Business Group

- Hardware, software and service
- After-sales

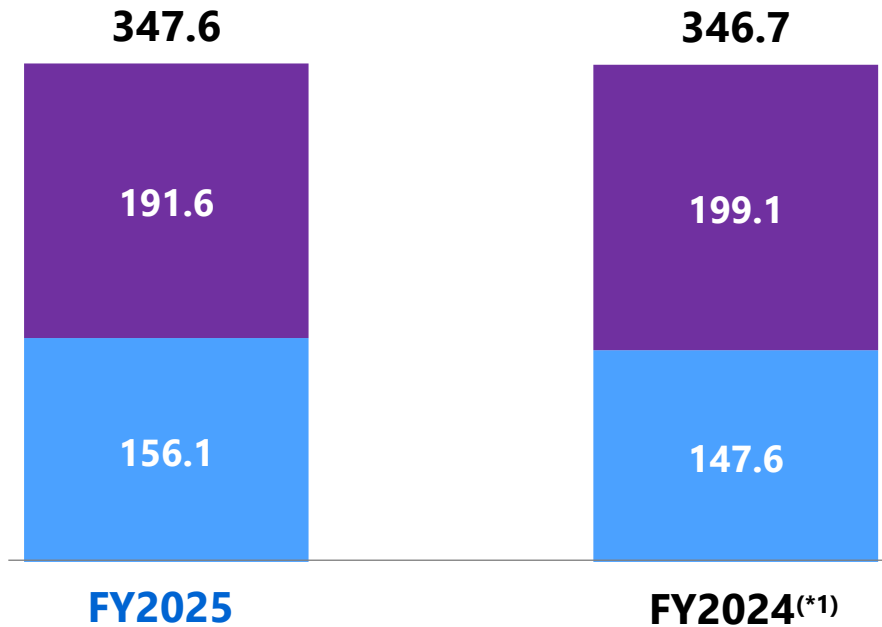

## Workplace Solutions Business Group

- Hardware and software<sup>(\*2)</sup>
- After-sales

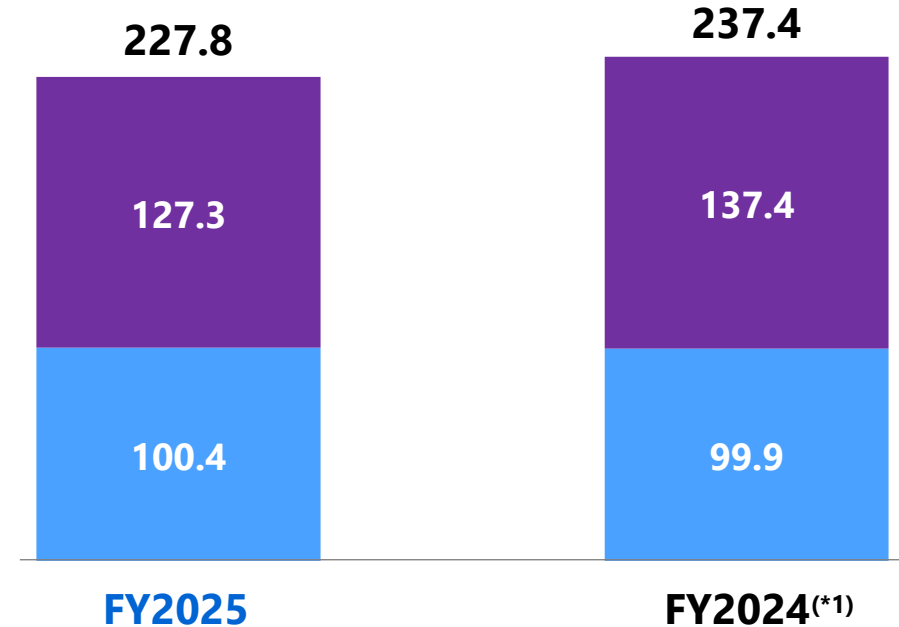

(\*1) The business related to MFP for the domestic market, which was included in the Workplace Solutions Business Group until FY2024, has been transferred to the Retail Solutions Business Group from FY2025. Therefore, the actual results for FY2024 are shown as the amount after segment reclassification.

(\*2) Sales of Inkjet head business, which are included in the hardware and software sales of the Workplace Solutions Business Group, have been excluded from consolidation since July 2024 due to the business transfer.

# FY2026 Forecast : Impact of Currency Exchange Rate

	Premise Rate	Effect of depreciation by 1 yen	
	FY2026	Net Sales (Annual)	Operating Profit (Annual)
<b>US\$</b>	<b>150 yen</b>	<b>+1.8 billion yen</b>	<b>△0.15 billion yen</b>
<b>EUR</b>	<b>175 yen</b>	<b>+0.3 billion yen</b>	<b>+0.13 billion yen</b>

# FY2026 Forecast : Capital investment<sup>(\*)</sup>, Depreciation and Amortization, R&D expenses

(Billions of yen)

## Capital investment<sup>(\*)</sup>, Depreciation and Amortization

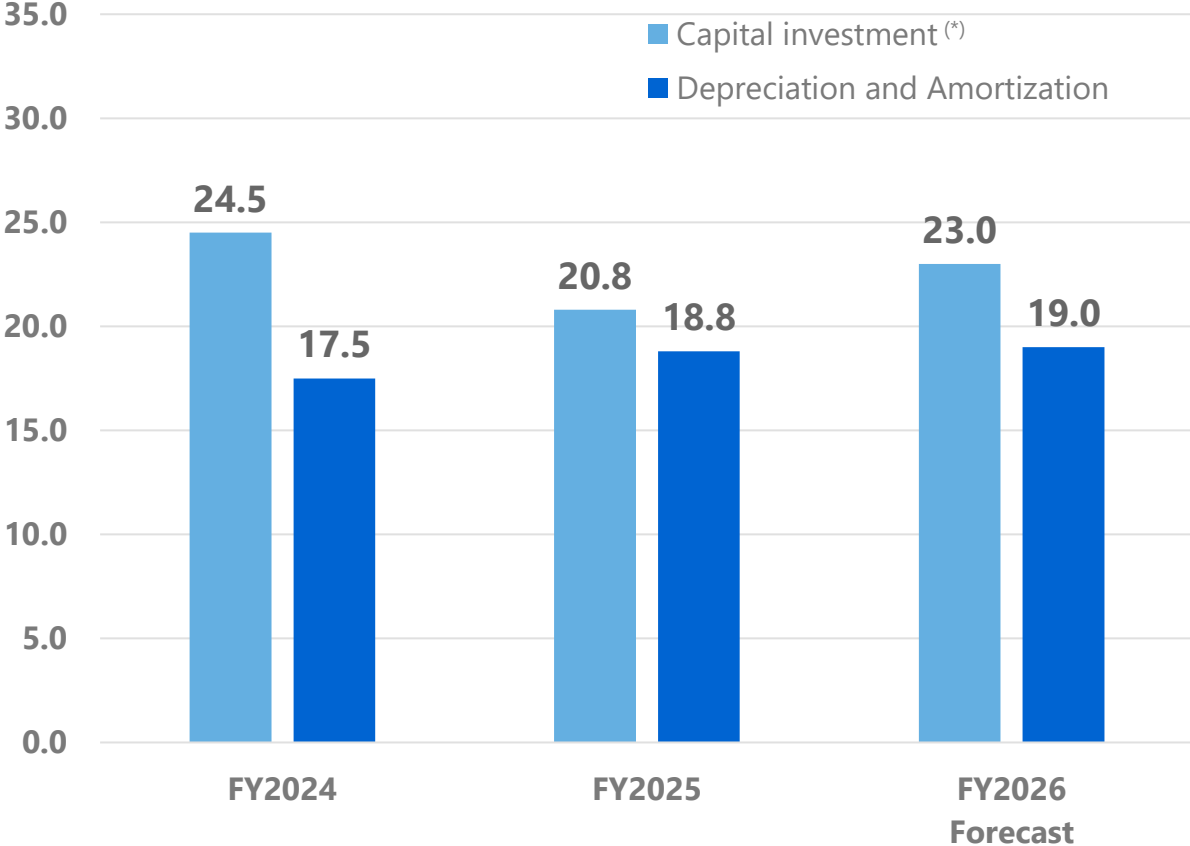

## R&D expenses

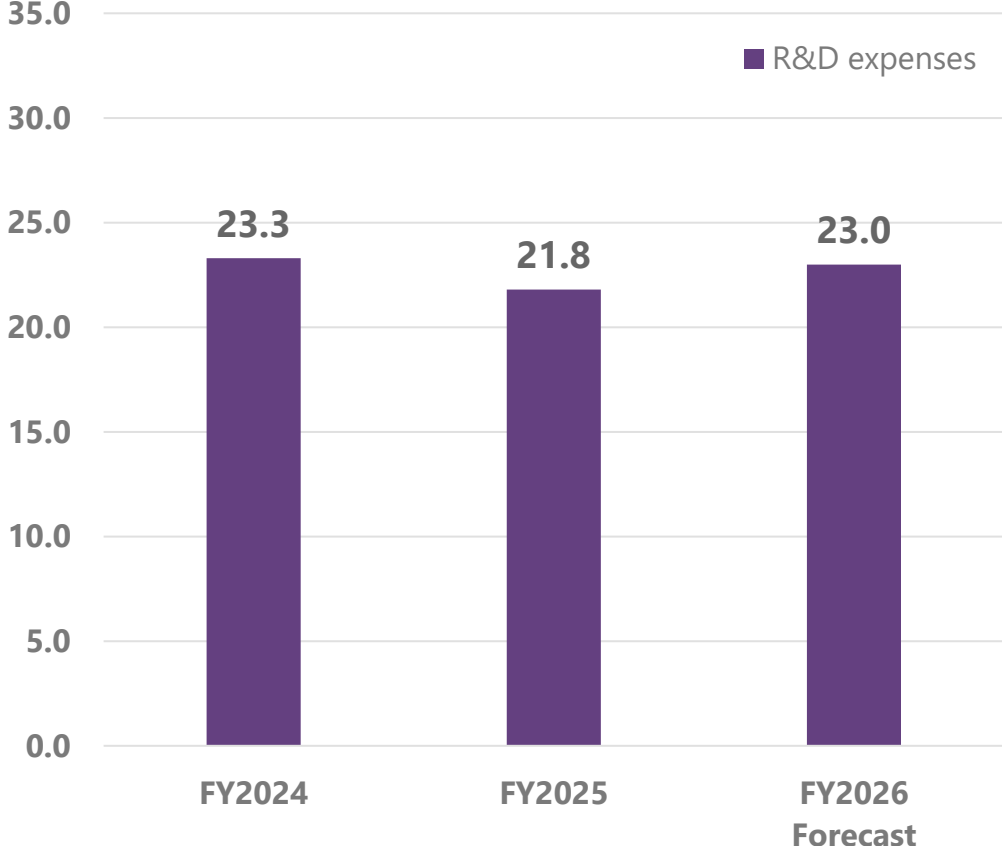

(\*) The increase amount of tangible assets and intangible assets

Forward-looking statements concerning Toshiba Tec's future performance contained in this presentation represent certain reasonable assumptions based on economic, financial and competitive data and information currently available. However, actual results will be affected by the business and competitive environment and may differ materially from forecasts.



Toshiba Tec Group Philosophy

# Creating with You